

HRV160 wall-mounted fume extractor with self-supporting arm and fan

🔧 Sectors [Welding, Powder blowing,](#)

🔧 Applications [Fix](#)

🔧 Issues [Fumes, Powders](#)



COD: HRV1600000000000

The fume and volatile dust extraction station consists of a wall bracket, centrifugal fan, and **HRV160 self-supporting articulated extraction arm**.

Insight

HRV160 wall-mounted fume extractor with self-supporting arm and integrated fan, a practical and economical solution for efficiently and conveniently solving the problem of fumes produced by a single welding station or other professional processes that produce fine volatile dust.

Thanks to two external pantographs, the extraction arms of the HRV160 series can be moved smoothly and easily in all directions and maintain the desired position for maximum working comfort. Stability and precision are guaranteed by the plastic spring and clutch system.

Thanks to the powerful and concentrated extraction near the hood, the respiratory tract is protected from fumes and dust from welding, grinding, and other professional processes.

The extraction hood is made of plastic and is easy to position thanks to its convenient ergonomic handle.

Extractor fan: YES / to be connected to a circular section exhaust pipe.

Advantages

- integrated extractor fan no system required
- Stability thanks to double pantograph
- Rigid pipes, so no components are immersed in the extracted fluid
- minimal pressure drops
- Simple installation

Flow rate: 1500 m³/h

Motor: 1500 W - 220V/1f/50Hz

Installation: wall-mounted

Integrated extractor fan: YES / to be connected to circular section exhaust pipe

Maximum operating temperature: 60°C



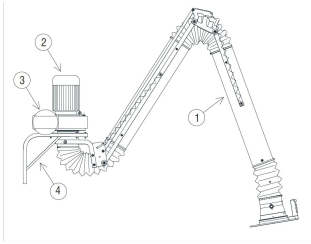

Structure

- hRM160 arm (1)
- aspirators (2) complete with square-round reduction (3)
- bracket (4)



Dimensions

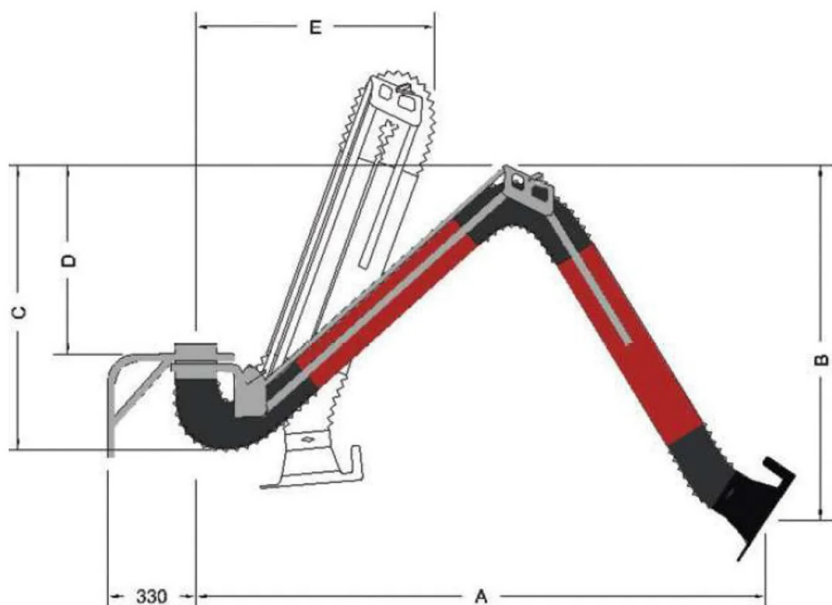

Measures

Code	A mm	B mm	C mm	D mm	E mm
HRV160200000000	2168	1201	903	568	729
HRV160300000000	3168	1701	1373	1038	900
HRV160400000000	4168	2201	1843	1508	1071



Technical Data

Code	Nominal flow rate m ³ / h	Long arm meters	Pipe diameter mm
HRV160200000000	1250	2	160
HRV160300000000	1250	3	160
HRV160400000000	1250	4	160



Related accessories



EHRM Extension 160mm

EHRM16000000000

Welded steel extension with wall bracket for wall-mounted suction arms.



Related spare parts



Wall bracket for industrial extraction arm Black

Professional wall bracket for industrial suction arms.

