

# GSH exhaust gas extractor with manual mechanical retractor [heavy-duty vehicles]



🔗 Sectors [Exhaust gases](#)

🔗 Applications: [Fix](#)

🔗 Issues [Exhaust gases](#)

COD: GSH000000000000

The **GSH exhaust gas extractor** with reel is the most effective and easy-to-install solution for solving exhaust emissions from heavy-duty trucks on the shop floor, or during temporary stationing, by sucking directly at the source thanks to a hose and a nozzle to be connected to the muffler.

## Detailed description

The **GSH exhaust gas extractor** with coiler comes already assembled and complete with:

- Sturdy painted steel drum complete with side discs, hose connection and brackets for wall mounting
- High-efficiency centrifugal exhaust fan in execution directly coupled to three-phase motor. Max power 1.1kW for longer pipes and 0.75 kw for pipes up to 7.5mt.
- Air flow rate 1400 mc/h
- Flexible rubber-armored hose with reinforced nylon anti-crush spiral. Certified use for exhaust gas extraction systems with coilers. Withstands temperatures up to 200°C. 150 mm diameter
- Rubber nozzle with cap for hose connection to exhaust muffler (other nozzles on request to better fit the system)

The suction hose when not in use can be mechanically rewound by the operator.

Rollers with mechanical rewinding for heavy vehicles are available with hose diameter from 150 mm and with lengths up to 12.5 m, depending on the models.



## Dimensions

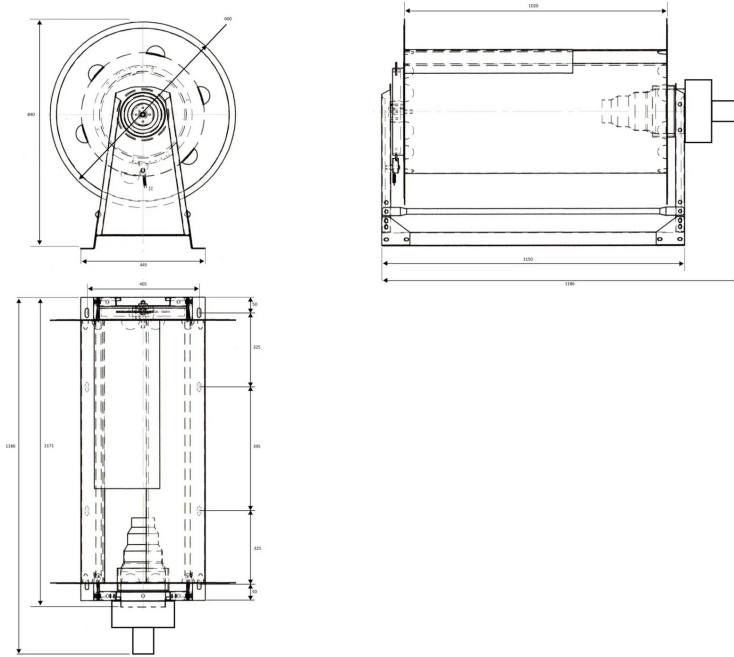

Code	A	ØB	ØC	D	E	G	H	I	N	ØL	ØF	ØO	ØM	ØR	P	●	S	Ø
	mm	mm	mm	mm	mm	mm	mm	mm	mm	mm	mm	mm	mm	mm	mm	mm	mm	mm
GSH15010T000000	960	150	450	845	1600	365	366	365	12	40	1096	780	455	180	300	350	735	150
GSH150125T00000	960	150	625	1030	1540	322	322	322	12	30	966	925	530	180	300	355	661	150

## Technical Data

Code	Power kW	Nominal flow rate m <sup>3</sup> / h	Weight kg	Pipe diameter mm	Tube length meters
GSH15010T000000	0.75	1430	79	150	10
GSH150125T00000	1.1	1430	81.75	150	12.5

