

# Use and Maintenance Guide

## SOILPRO

Oil Mist Filter  
with extractor fan

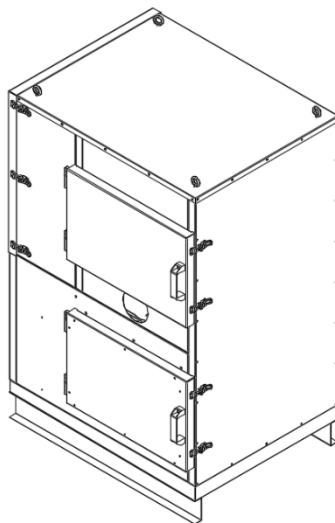

**CE**

## Summary

2.	Introduction .....	3
2.1	Purpose of the guide .....	3
2.2	Definitions .....	3
2.3	Privacy .....	4
2.4	Regulatory references.....	4
2.5	Reporting errors discrepancies .....	4
3.	Safety and accident prevention regulations.....	4
3.1	General informations .....	4
3.2	Rules and general informations for safety.....	4
4.	Machine identification.....	6
5.	General description .....	6
6.	Noise Hazard .....	6
7.	Fire Hazard.....	7
8.	Technical and mechanical characteristics.....	7
8.1	Filter element data .....	8
8.2	Performances .....	8
8.3	Electrical characteristics.....	8
9.	Intended use .....	9
10.	Packaging procedures.....	9
11.	Transportation and handling .....	9
12.	Installation and commissioning.....	10
12.1	Positioning.....	10
12.2	Assembly.....	10
12.3	Rotation direction controlone .....	11
13.	Preparation for use.....	11
14.	Use.....	11
15.	Maintenance .....	12
15.1	Collection tank.....	12
16.	Assembly / disassembly .....	14
17.	Searching for and eliminating system defects system defects .....	14
18.	Spare parts.....	15
19.	Waste disposal.....	15
	Annex 1 – Maintenance Sheet .....	16
	Annex 2 - Reporting discrepancies in publication .....	18

## 1. Introduction

### 1.1 Purpose of the guide



The "Use and Maintenance Manual" describes all the steps necessary for the correct installation and use of the machine, with particular attention to safety and environmental protection. This manual must be read carefully before operating the machine and kept near the machine itself, available to the user or maintenance personnel. The machine has been designed and built in compliance with industry safety standards. As proof of this, the machine has been affixed with the "CE" mark, which ensures compliance with the Machinery Directive. Any unauthorized tampering with the device and/or any intervention carried out by non-specialized personnel could compromise its proper functioning and significantly alter its performance.

Additional information not contained in this manual can be requested directly to  
**Secureair® by Gamma Impianti™ S.R.L.**  
 Via Stroppiana n° 15 10071 Borgaro T.se (TO) - Tel. +39 011 4502031 – Fax +39 011 4703927  
 - P.IVA IT05898600019  
 E-mail : [info@secureair.it](mailto:info@secureair.it)  
 Web : [www.secureair.it](http://www.secureair.it)

- The information contained in this manual is the property of Secureair® by Gamma Impianti™ S.R.L.
- Reproduction, even partial, is prohibited without the prior written authorization of Secureair® by Gamma Impianti™ S.R.L.
- Secureair® by Gamma Impianti™ S.R.L. assumes no responsibility for any errors that may appear in this document and reserves the right to modify the characteristics of the product described in this manual without prior notice.
- Secureair® by Gamma Impianti™ S.R.L. declines all responsibility for any damage suffered by third parties due to incorrect installation, improper use, removal, or deactivation of the installed safety devices.
- Under no circumstances shall Secureair® by Gamma Impianti™ S.R.L. be held liable for accidents or damage to the machine and its components, as described in this document, if caused by or resulting from the incorrect use of the information contained in this manual.
- Secureair® by Gamma Impianti™ S.R.L. assumes that the systems where the machine is to be used comply with current occupational health and safety regulations.

### 1.2 Definitions

Throughout this manual, the terms CAUTION, WARNING, and NOTE are used to highlight instructions or information that is considered critical or unusual.

	<p>WARNING          INFORMATION OR PROCEDURE THAT, IF NOT STRICTLY FOLLOWED, MAY RESULT IN PERSONAL INJURY OR DEATH.</p>
	<p>WARNING          INFORMATION OR PROCEDURE THAT, IF NOT STRICTLY FOLLOWED, MAY CAUSE SERIOUS DAMAGE TO THE MACHINE OR INDIVIDUAL COMPONENTS.</p>
	<p>Note          Information or procedure that can facilitate or simplify maintenance operations, or any part of the text that is particularly important and should be highlighted.</p>

**Figura 1 - Symbols used in this manual**

### 1.3 Privacy

The technical information contained in this manual is the property of Secureair® by Gamma Impianti™ S.R.L. and must be considered confidential: therefore, its disclosure and reproduction, even partial, is prohibited without the written authorization of Secureair® by Gamma Impianti™ S.R.L.

### 1.4 Regulatory references

The purification machine described in this publication complies with the following standards:

Machinery Directive **2006/42/EC**

Low Voltage Directive **2014/35/EC**

Machinery Safety **EN ISO12100:2010**

Machinery Safety - Electrical Equipment of Machines **EN60204-1**

Electromagnetic Compatibility **2014/30/EC**

### 1.5 Reporting errors discrepancies

In order to include the most up-to-date information in our manuals, our company analyzes the reports we receive. Operators are invited to report any inaccuracies by email to the addresses mentioned above.

## 2. Safety and accident prevention regulations

### 2.1 General informations

This section contains some basic safety rules that operators and maintenance personnel must strictly follow to avoid injury to persons or damage to the machine, including serious damage.

Secureair® by Gamma Impianti™ S.R.L. cannot foresee every situation that could create a potential hazard during the use or maintenance of the system; for this reason, the safety messages included in the manual and/or on the equipment labels may not include all possible safety precautions.

The safety information contained in this manual must in any case be supplemented by the specific provisions of the law and the relevant regulations issued by the public bodies responsible for prevention.

### 2.2 Rules and general informations for safety

- ❖ Strictly and carefully follow the safety instructions provided in this manual.
- ❖ It is recommended to use the personal protective equipment indicated in the relevant regulations.
- ❖ After removing the product from its packaging, check that it is intact. If there is any damage or if you have any doubts, contact a qualified professional immediately.
- ❖ If the product has suffered a strong impact or has fallen, check all its parts.
- ❖ If there are structural deformations, malfunctions, or damaged components, contact an Authorized Service Center.
- ❖ Do not install the device in locations with explosive or aggressive atmospheres, unless it is specifically designed and built for such use. Utilizzare la macchina con una temperatura ambientale (al motore) compresa tra 0°C e +40°C e comunque con un'umidità relativa massima che non superi 85%. Mettere in funzione la macchina esclusivamente su terreni o pavimentazioni orizzontali.
- ❖ The machine and the surrounding area must be free of hazardous deposits and materials in general. If the environmental conditions for which the machine is designed to operate are modified, the manufacturer is not liable for any malfunctions or possible risks and damage that may occur.
- ❖ Before performing any cleaning and/or maintenance, turn off the power switch. Ensure that the power supply has been disconnected and that the switch cannot be accidentally reset.
- ❖ The use of any electrical appliance requires compliance with certain basic rules, including:
  - ❖ it must not be touched with damp or wet hands;
  - ❖ it must not be touched with bare feet.
- ❖ Adhesive labels indicating potential hazards or recommendations for use must not be removed.
- ❖ The machine must undergo periodic checks as indicated in the user and maintenance manual.

- ❖ The machine must only be used by authorized and trained personnel; the same precaution also applies to persons who have to perform maintenance. When performing maintenance, adopt all possible safety rules, precautions, and all the measures and procedures indicated for the individual operations; during maintenance, require that any persons present as collaborators adopt the necessary safety measures.
- ❖ The machine, or its components, must not be modified without the prior written authorization of Secureair® by Gamma Impianti™ S.R.L. If modifications are made to the machine and its components without the prior written authorization of Secureair® by Gamma Impianti™ S.R.L., all forms of warranty will be void. Secureair® by Gamma Impianti™ S.R.L. is not liable for any malfunction of the machine or damage to property or persons if unauthorized modifications are made.
- ❖ Secureair® by Gamma Impianti™ S.R.L. is not liable for any use other than that for which the machine was designed. For information on the use of the machine covered by this manual, see Chapter 6 - Intended use.
- ❖ Ensure that all guards and covers are correctly secured; if they are damaged, replace and repair them immediately. Do not approach equipment without guards and do not remove covers when the electrical circuits are live.
- ❖ At the end of maintenance and/or repair operations, before reconnecting the machine to the power supply, the person in charge of the work must ensure that the guards and safety devices are correctly installed.
- ❖ Wear suitable clothing and personal protective equipment during cleaning and maintenance operations. Non effettuare operazioni sulla macchina quando è in funzione e senza aver verificato che la macchina è scollegata dalla rete elettrica.
- ❖ Use approved equipment and tools.
- ❖ Check that the safety devices fitted to the machine, or parts thereof, are kept in perfect working order.
- ❖ Only use suitable devices that comply with regulations for moving the machine.
- ❖ Do not attach the machine to other foreign objects.
- ❖ Do not place any tools and/or objects on the machine.
- ❖ Do not introduce foreign or sharp objects of any kind that could damage or obstruct the filter section, and do not smoke near the suction points.
- ❖ The company safety manager must ensure that the personnel responsible for using the machine have read and fully understood this manual in its entirety.
- ❖ The company safety manager is responsible for verifying the company's risk status in accordance with Legislative Decree 81/08.

	<p><b>Disconnect the power supply before performing any routine or non-routine maintenance on the machine; all operations must be performed with the machines in a safe condition.</b></p>
	<p><b>Contact with electrical conductors that are not adequately insulated or protected can be fatal. Only qualified personnel are authorized to perform work on electrical systems and components.</b></p>
	<p><b>During maintenance, safely isolate the circuits and devices on which you are going to work from the power supply.</b></p>

	<p>VERIFY THAT THE APPLIANCE IS INSTALLED AND USED IN ACCORDANCE WITH LOCAL LAWS AND REGULATIONS.</p>
	<p>Secureair® by Gamma Impianti™ S.R.L. accepts no responsibility for accidents resulting from use of the PRODUCT IN QUESTION under the following conditions:</p> <ul style="list-style-type: none"> <li>- REMOVAL or modification of safety devices;</li> <li>- use of the device not in accordance with the INSTRUCTIONS provided by Secureair® by Gamma Impianti™ S.R.L.;</li> <li>- modification of the device without PRIOR AUTHORIZATION from Secureair® by Gamma Impianti™ S.R.L.;</li> <li>- use of accessories and spare parts not supplied by Secureair® by Gamma Impianti™ S.R.L.;</li> <li>- use of the device for purposes other than those for which it was intended.</li> </ul>

### 3. Machine identification

The machine is identified by the CE label affixed to the structure.  
The label shows the following information:

- ❖ Manufacturer's logo
- ❖ Machine model
- ❖ Serial number
- ❖ Power supply
- ❖ Amperage
- ❖ Year of manufacture
- ❖ Total weight

### 4. General description

The oil mist filter consists of a suction section, a filter unit, an air evacuation section, and an oil collection area.  
The filter unit structure is made of high-quality galvanized sheet metal panels punched with a controlled punching machine and pressed with a 6-axis bending machine. The panels are joined by electric welding or bolted together to form a single self-supporting sealed box.

The panels are sealed with special oil-resistant silicone.

The air flow to be purified is transported to the filter through a special suction line, thanks to the vacuum created inside the structure by the suction unit. The polluted air enters from the side at the bottom into a special cavity where a calm zone is created. By means of a deflector located inside, the flow is forced through a path that facilitates the fall of the oil into the tank below.

The filtering section separates and collects the oily particles present in the flow to be purified through the phenomenon of coalescence.

The filtering section consists of a series of filters suitable for filtering oil mists.

The filter elements contained inside the filter are:

- Flat filter with metal septum;
- Synthetic pocket filter with F9 efficiency.
- HEPA absolute filter with H13 filtration rating.

All filter elements are positioned inside the structure and inserted into special guides that make them easy to remove for replacement and maintenance.

Once it has passed through the filter section, the purified air flow passes through the extractor fan and is pushed through the HEPA absolute filter and the structure.

At the bottom, there is a galvanized sheet metal discharge hopper that reduces the air speed and collects the liquid present in the flow to be extracted. The hopper is equipped with a pipe with a tap for draining the liquid into a special collection bin.

The oil mist filter must not operate continuously, but requires downtime to allow the oil trapped in the pockets to settle in the collection hopper by coalescence.

### 5. Noise Hazard

The noise is generated by the electric fan located inside the filter. An additional source of noise is the air flows coming from the collection devices: in order to limit the noise emitted outside the entire system, the speed of these flows is kept as low as possible, compatibly with the need to ensure filtering efficiency and avoid the possible deposit of the substances transported.

	<p><b>Noise levels are measured inside the factory using special devices calibrated at a distance of 1 meter.</b>  <b>Noise levels vary depending on the type of extractor used.</b>  <b>This may vary depending on the final location of the filter.</b></p>	<p><b>73/78 dB</b></p>
---	---	------------------------

## 6. Fire Hazard

The system is subject to fire risk due to the presence of incandescent particles contained in the air flow to be treated.

When the processes do not allow this circumstance to be completely ruled out, it will be necessary to take additional measures to detect the presence of any sparks or to adopt suitable alternative devices.

	<p><b>CAUTION</b>  <b>SUCTION POINTS MUST BE LOCATED AWAY FROM POINTS WHERE INCANDESCENT PARTICLES, SPARKS, AND OTHER ELEMENTS THAT COULD CAUSE FIRES MAY BE SUCTIONED..</b></p>
---	--

## 7. Technical and mechanical characteristics

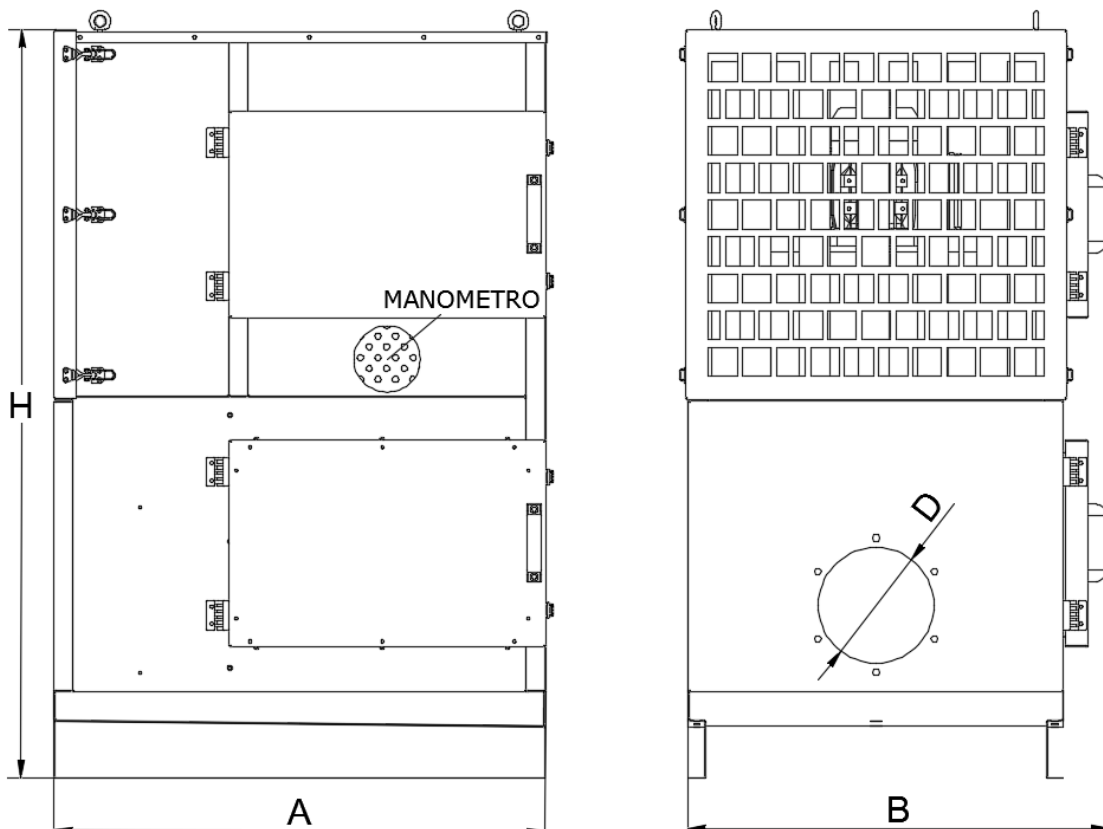

Image 3 - Reference dimensions

<i>Model</i>	<i>A</i>	<i>B</i>	<i>H</i>	<i>D Entrance ø</i>	<i>Weight</i>
	<i>[mm]</i>				<i>[kg]</i>
<b>SOILPRO11</b>	855	737	1.295	150	150
<b>SOILPRO15</b>	855	737	1.295	200	160
<b>SOILPRO22</b>	855	737	1.295	250	170

**Tabella 1 - Dimensions GOF**

<i>Model</i>	<i>Flow rate [m<sup>3</sup>/h]</i>	<i>Power [kW]</i>	<i>Volt [V] THREE-PHASE</i>	<i>Current [A]</i>	<i>Power cable [mm<sup>2</sup>]</i>	<i>Residual head [Pa]</i>	<i>Nr. Of pockets</i>	<i>Nr. Of metal filters</i>	<i>Nr H13 filters</i>
<b>SOILPRO11</b>	1.000	1.1	400/230	2,5	4 x 1,5	600	1	1	1
<b>SOILPRO15</b>	2.000	1.5	400/230	3,3	4 x 2,5	600	1	1	1
<b>SOILPRO22</b>	4.000	2.2	400/230	4,6	4 x 2,5	600	1	1	1

**Tabella 2 - Performances and features GOF**

## 7.1 Filter element data

<b>METALLIC FILTER</b>	
Efficiency class (CEN EN779):	<b>G2</b>
Efficiency group EN ISO 16890:2016	<b>GROUP ISO ePM<sub>10</sub> 50% (ePM<sub>1</sub> 1% - ePM<sub>2,5</sub> 2% - ePM<sub>10</sub> 12%)</b>
Average gravimetric efficiency:	<b>70%</b>
Maximum operating temperature:	<b>200°C</b>
Relative humidity:	<b>100%</b>
Initial pressure drop:	<b>10 Pa</b>
Recommended final pressure drop:	<b>150 Pa</b>
Maximum pressure drop:	<b>300 Pa</b>
Recommended filtration speed:	<b>1,5 m/s</b>

**Tabella 3 – wire mesh**

<b>Pockets</b>	
Efficiency class (CEN EN779):	<b>F9</b>
Average gravimetric efficiency:	<b>98%</b>
Initial pressure drop:	<b>160 Pa</b>
Recommended final pressure drop:	<b>600 Pa</b>
Maximum operating temperature	<b>80° C</b>

**Tabella 4 - Rigid pocket filter F9**

<b>ABSOLUTE EXPULSION FILTER H13</b>	
Efficiency class (CEN EN779):	<b>H13</b>
Average gravimetric efficiency:	<b>99,99%</b>
Initial pressure drop:	<b>600 Pa</b>
Recommended final pressure drop:	<b>1000 Pa</b>
Maximum operating temperature	<b>90° C</b>

**Tabella 5 – Absolute filter H13**

## 7.2 Performances

Performance is measured using instruments that are calibrated and certified periodically by external laboratories. For machine performance, refer to Chapter 5, Table 2.

## 7.3 Electrical characteristics

The purifiers are designed to be powered by a three-phase mains voltage of 230/400V–50Hz.

	<p><b>WARNING:</b>          DISCONNECT FROM THE MAINS POWER SUPPLY BEFORE PERFORMING ANY WORK.</p>
---	--

	<p><b>WARNING:</b>          IF THE MAINS VOLTAGE IS 230V/50Hz THREE-PHASE, IT IS NECESSARY TO INTERVENE ON THE TERMINAL BLOCK OF THE FAN'S ELECTRIC MOTOR BY CHANGING THE POSITION OF THE JUMPERS AS SHOWN IN THE FIGURE BELOW. ONLY QUALIFIED PERSONNEL ARE AUTHORIZED TO PERFORM WORK ON ELECTRICAL SYSTEMS AND COMPONENTS.</p>	<p>230V – Triangle Δ</p> 	<p>400V – St Y</p> 
---	---	---	--

Tabella 6 - Caratteristiche elettriche

Power cable: see Table 2

Motor electrical characteristics: see Table 2

Wiring diagram: see section 11.3

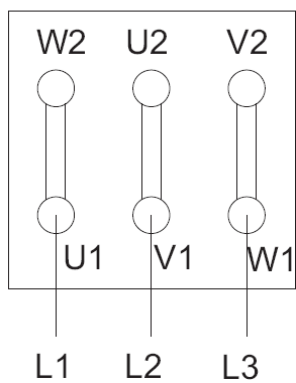
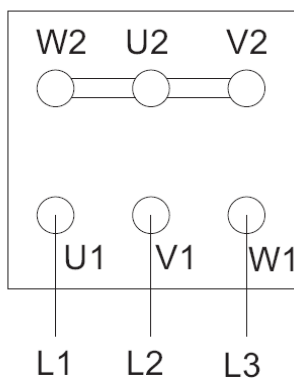
## 8. Intended use

The machine is designed and manufactured for the extraction and filtration of oil mists and fumes from machine tools.

The machine in question is intended for use with: Oil Mists

	<p><b>WARNING:</b>  <b>ANY OTHER OPERATION OR WORKING IN THE VICINITY OF THE SUCTION POINTS IS PROHIBITED AS IT MAY CAUSE DAMAGE OR RISK OF FIRE.</b></p>
---	---

## 9. Packaging procedures

Unless otherwise requested by the customer, the machine is shipped fully assembled

- - Filter on pallet. Covered with film

## 10. Transportation and handling

For transport, follow these instructions:

- Do not stack materials on top of the packaging;
- Do not expose the materials to atmospheric agents.

	<p><b>WARNING:</b>  <b>TO MOVE THE PURIFIER, USE APPROPRIATE MECHANICAL HANDLING EQUIPMENT IN ACCORDANCE WITH CURRENT REGULATIONS.</b></p>
---	--

## 11. Installation and commissioning

### 11.1 Positioning

The installation area must be accessible for cleaning, maintenance, and repair, and must be level and able to support a distributed and concentrated load suitable for the machine installed.

In the immediate vicinity of the machine, in a position agreed with the manufacturer, the customer must provide a power supply for the vacuum cleaner motor of suitable power.

This machine is manufactured using electrical components and accessories to ensure a degree of protection against the penetration of solid and liquid bodies IP 55, and therefore, in order to comply with the installation conditions required by standards CEI64-8, CEI EN 60439-1, CEI EN 61439-1 and 2, it can be used in:

- ordinary, damp or wet environments,
- zone 2 NE.

**This machine cannot be placed in ATEX classified locations.**

### 11.2 Assembly

The following operation must be performed by at least three people.

For correct installation of the purifier, follow the steps listed below:

- Remove the filter components from their packaging;
- Position the filter as desired; Power supply connection

	<p>WARNING          ALL OPERATIONS RELATING TO CONNECTING THE UNIT TO THE ELECTRICAL NETWORK AND STARTING IT UP MUST BE PERFORMED BY QUALIFIED PERSONNEL.</p>
	<p>WARNING          THE MAIN NETWORK MUST BE PROTECTED UPSTREAM AGAINST INDIRECT DAMAGE IEC 204-1</p>

	<p>WARNING          BEFORE CONNECTING THE PURIFIER TO THE POWER SUPPLY, CHECK THAT THE POWER SUPPLY VOLTAGE IS 400V/50HZ THREE-PHASE, OTHERWISE FOLLOW THE INSTRUCTIONS PROVIDED IN THE WARNINGS CONTAINED IN PAR.5.2</p>
---	---

#### **Machines with vacuum cleaner but without electrical panel and/or circuit breaker**

Il cliente deve provvedere a disporre sulla linea di alimentazione un interruttore di sicurezza idoneo e correttamente dimensionato, posizionato a monte dell'interruttore On/Off dell'aspiratore.

Per il funzionamento normale la macchina deve essere prevista di pulsante di marcia e pulsante di arresto.

#### **Machines with vacuum cleaner equipped with electrical panel and/or circuit breaker**

When installed, the machine is complete with all the electrical components necessary for its operation, including thermal and magnetic protection for the various elements inside the panel.

Inside the panel, once the plug has been disconnected, the door opens and access is gained to the power supply terminal block, designed for connection to the input line, marked L1-L2-L3, and to the protective cover bearing the symbol as well as to the terminal for connection to the grounding system, marked in yellow-green, with the letters

PE and the symbol 



The terminals for the power supply line and the relative grounding are designed for 6 mm<sup>2</sup> conductors.





Figura 2 - Electrical diagram

Once the connections have been made, taking care to tighten the terminals securely, all protections must be restored and checked to ensure that the installed conductors do not have any damage to their insulation or exposed live parts.

The power supply line to the machine panel must be sized and protected in such a way as to ensure both operation when the motor starts (start-up) and protection against indirect contact coordinated with the resistance value of the existing earth leakage system. Therefore, a power supply with a conductor cross-section of at least 6 mm<sup>2</sup> protected by a 3 x 32 A I<sub>dn</sub>=0.03 differential magnetothermal device must be provided.

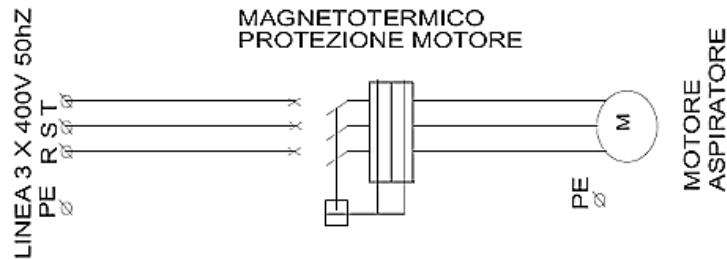
It must also be ensured that the overall voltage drop with the machine in operation guarantees a voltage of at least 375 V.

Once the power supply line has been connected, before starting up the machine, the correct direction of rotation of the motor must be checked in order to ensure the correct functioning of the entire system.

	<p><b>WARNING</b>          FOR NORMAL OPERATION, THE MACHINE MUST BE EQUIPPED WITH A START BUTTON AND A STOP BUTTON.</p>
---	--

### 11.3 Rotation direction controlone

To perform this check, proceed as follows:

1. Ensure that the machine is able to operate correctly in terms of positioning and assembly, and that there are no foreign objects inside the equipment.
2. Turn on the machine using the start button and check that the direction of rotation of the electric motor or electric fan matches that indicated by the arrow above.
3. Turn off the machine using the stop button.
4. If the rotation is in the opposite direction, reverse two power phases by adjusting the extractor fan located in the upper compartment. Repeat steps 1 to 3.

## 12. Preparation for use

Preparation for use of the purifier essentially consists of:

- ❖ connecting it to the vacuum cleaner's power supply line, see section 9.3;
- ❖ connecting it to the suction line;

## 13. Use

	<p><b>WARNING</b>  <b>CAREFULLY CHECK THAT THE SUCTION POINTS CONNECTED TO THE MACHINE ARE OPEN, FREE OF FOREIGN OBJECTS, AND UNABLE TO SUCTION ANYTHING NOT COVERED IN CHAPTER 6, "INTENDED USE."</b>  <b>IMPROPER USE MAY CAUSE DAMAGE TO THE PURIFIER AND WILL ALSO RESULT IN THE IMMEDIATE TERMINATION OF THE WARRANTY.</b></p>
---	---

Press the power switch.  
 When finished, press the power switch to turn off the machine.

## 14. Maintenance

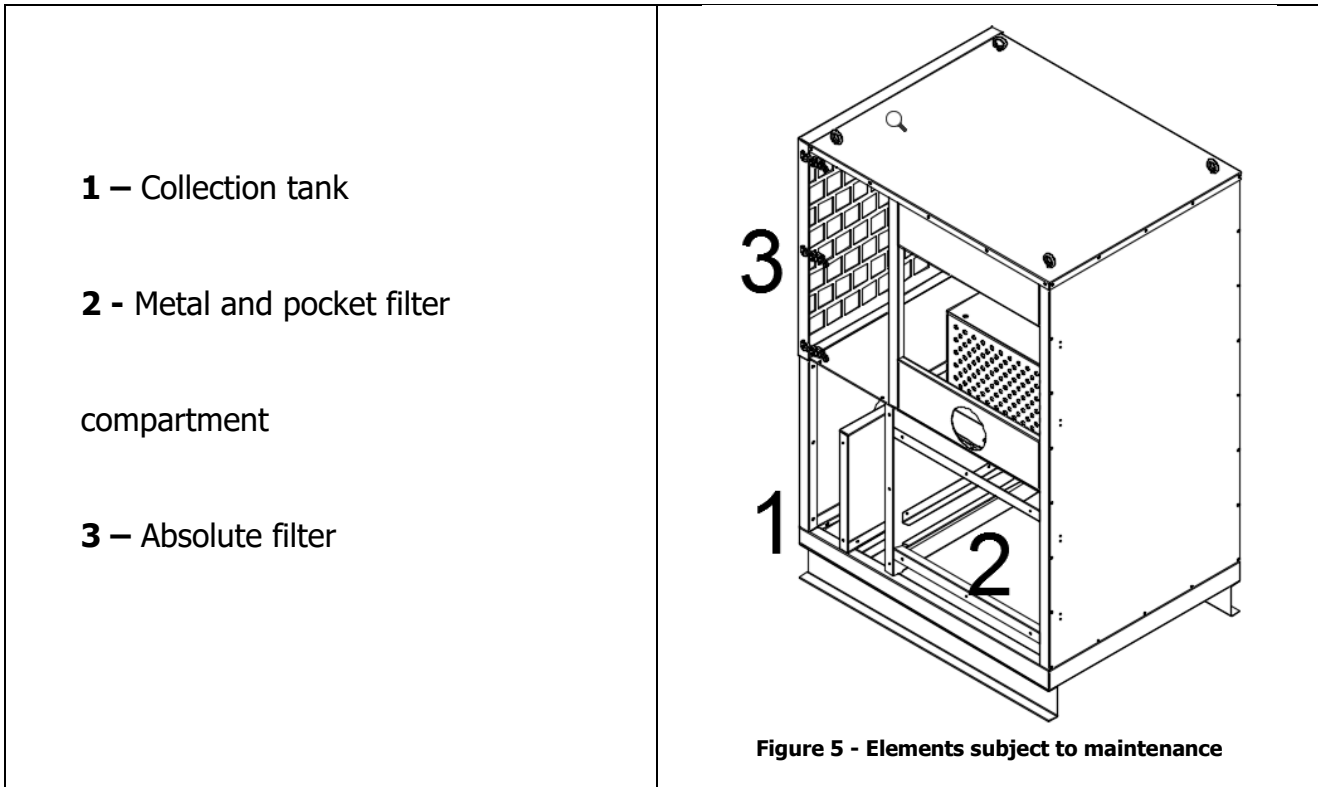

	<p><b>WARNING</b>  <b>CAREFULLY READ CHAPTER 2 OF THE INTRODUCTION BEFORE PERFORMING ANY MAINTENANCE OPERATIONS.</b></p>
	<p><b>WARNING</b>  <b>ALL MAINTENANCE AND REPAIR WORK MUST BE PERFORMED BY QUALIFIED PERSONNEL WHO HAVE READ THE USER AND MAINTENANCE MANUAL.</b></p>

### 14.1 Collection tank

With the system switched off, empty the impurity collection container (item no. 1).  
 To collect the liquid present in the filter pockets, please note that the filter requires a period of downtime to allow the oil collected in the pockets to separate from them by coalescence and settle in the tank. The tank is drained by means of two 3/4" hoses located at the bottom. Any external oil drainage devices are the responsibility of the customer.  
 For the disposal of the collected liquids, contact the relevant authorities or specialized companies. Filter inspection and replacement

	<p><b>WARNING</b>  <b>ALL MAINTENANCE AND REPAIR WORK MUST BE PERFORMED BY QUALIFIED PERSONNEL WHO HAVE READ THE USER AND MAINTENANCE MANUAL.</b></p>
---	---

	<p><b>WARNING</b>  <b>ALL MAINTENANCE AND REPAIR WORK MUST BE PERFORMED BY SPECIALIZED PERSONNEL EQUIPPED WITH APPROPRIATE PERSONAL PROTECTIVE EQUIPMENT (PPE) SUCH AS GLASSES, MASKS, GLOVES, AND NON-SLIP SHOES. EVALUATE OTHER MEANS OF PERSONAL PROTECTIVE EQUIPMENT DEPENDING ON THE POLLUTANT TREATED BY THE FILTER.</b></p>
---	--

Access to the filters is via the filter compartment doors located at the front of the purifier structure. Filter maintenance and/or replacement is carried out periodically. The maintenance intervals are indicative as they depend on the oil load treated by the machine. Maintenance should be carried out approximately as indicated in the table below. The pressure gauge located on the filter indicates the clogging status of the filters. When it reaches the "red" zone, it is necessary to check the filters and, if necessary, replace them.

Time [hours]	Type of intervention	Filter
80	Check the integrity of the filters in the machine and their fastenings.	Metal mesh, droplet separator,
160	Wash metal filters.	pocket filters.
3000	Replace pocket filters.	Metal mesh, droplet separator.

To replace the filters, proceed as follows:

1. Turn off and disconnect the vacuum cleaner from the power supply.
2. Wait for the pockets and other filter elements to release the excess oil that has accumulated inside them.
3. Open the filter compartment door(s) located at the front of the lower part by unhooking the appropriate fasteners.
4. Remove the filters housed in the appropriate guides.
5. Clean the guide housings by removing excess deposits.
6. Insert the new filters in the predefined order, taking great care to ensure that they are correctly aligned in their seats.
7. Close the filter compartment door using the appropriate hooks, ensuring that it seals against the filter structure.
8. Start the fan and check that there are no leaks through the doors.

If there are any sealing problems, turn off the extractor fan, wait for the excess oil to settle, and repeat the procedure from step 7.

Metal filters. Be careful not to use high-pressure jets to avoid damaging the filters. If regeneration is not possible, replace the elements.

	<p><b>WARNING</b>  <b>AFTER COMPLETING MAINTENANCE OPERATIONS, CHECK THAT THE FILTER DOOR HAS BEEN INSTALLED AND SECURELY FASTENED.</b></p>
---	---

	<p>Note          Follow current waste regulations for the disposal of filter bags and filter cleaning residues.</p>
---	---

## 15. Assembly / disassembly

### Authorized personnel

The assembly and disassembly of the machine must be carried out by specialized, trained, qualified personnel who are familiar with the procedures described in this manual. A minimum of two personnel must be employed in these operations.

### Disassembly operations

To disassemble the machine correctly, follow the steps listed below:

- Disconnect the machine from the power supply;
- Disconnect the purifier from the suction line or other elements;
- Empty the collection tank.

## 16. Searching for and eliminating system defects system defects

There is a wide range of faults that may occur during the operation of the machine or its components. The most common faults are discussed below, indicating their probable causes and related corrective actions.

If, despite the suggested actions, the fault persists, we recommend contacting Secureair® by Gamma Impianti™ S.R.L., indicating the fault and the operating conditions. If, despite the suggested operations, the anomaly persists, we recommend contacting Secureair® by Gamma Impianti™ S.R.L., indicating the defect and the operating conditions of the machine. For troubleshooting and eliminating defects, see the table below. If the problem persists, contact the technical office, providing the product serial number.

Fault	Causes	Solution
<b>Machine shuts down</b>	Power failure	Check the connection to the power supply.
	Power failure because the circuit breaker has tripped	Reset the circuit breaker. If the problem persists, contact an authorized service center.
	Blown fuse	Replace the blown fuse.
	Disconnected cable	Contact an authorized technical service center.
<b>Insufficient suction</b>	Closed suction point shutters	Open the suction point shutters.
	Blocked exhaust grille	Remove the obstruction.
	Clogged filters	Turn off the fan and hold the extractor still for the time necessary for the oil to settle by coalescence.
	Reverse direction of fan rotation	Check section 9.4.
	Suction and/or discharge line blocked.	Remove the obstruction.
<b>The motor does not start</b>	Electrical panel not powered	Power up the electrical panel.
	Internal cable to electrical panel disconnected	Contact an authorized technical office.
	Motor burned out	Contact an authorized technical office.
<b>The panel is powered but the extractor fan does not work</b>	Check that the protective fuses are damaged	Replace the blown fuse.
	Internal cable to electrical panel disconnected	Contact an authorized technical office.

<b>Increased vibration or noise from the fan</b>	Motor burned out	Contact an authorized technical office.
	Miscellaneous	Contact an authorized technical office.
<b>Oily mist escapes from the exhaust</b>	Filters damaged	Replace the filters.
	Suction flow rate not suitable for the pollutant	Contact an authorized technical office.

**Tabella 7 - Searching for and eliminating system defects system defects**

## 17. Spare parts

Metal filter	592x492x23
F9 filter bag	592x492x292
H13 absolute filter	610x610x292

**Tabella 8 – Spare Parts**

## 18. Waste disposal

The waste produced by the system consists of dust residue with pollutant deposits and must be periodically disposed of by the user through an authorized carrier, after analysis of the waste. Contact the relevant authorities or specialized companies.

For the disposal of used filters, contact the relevant authorities or specialized companies.





## Annex 2 - Reporting discrepancies in publication

If you believe you have identified any errors or discrepancies in this publication, please send us the following form with a description of the anomaly you have found.

Article name:

Date:

N° review:

N° page:

Your data:

Description of directions:

Spedire questo foglio, completo nei suoi dati e con eventuali allegati, a:

Send this form, complete in its data and any attachments to:

Nous Vous prions d'envoyer cette page complète des éventuelles pièces jointes à :

Enviar este formulario, completo en sus datos a:

Secureair® by Gamma Impianti™ S.R.L.  
 Via Stroppiana, 15 - 10071 Borgaro T.se (TO) - Tel. +39 011 4502031 - Fax +39 011 4703927  
 Email: [info@secureair.it](mailto:info@secureair.it) – website: [www.secureair.it](http://www.secureair.it)



**By GAMMA IMPIANTI™ s.r.l**  
Via Stroppiana n° 15 10071 Borgaro T.se (To) - Italy  
Tel. +39 011 4502031 Fax +39 011 4703927  
P.IVA IT05898600019  
E-mail : [info@secureair.it](mailto:info@secureair.it)  
Web : [www.secureair.it](http://www.secureair.it)