

High pressure welding fume extractor GTC1A22

🔧 Sectors **Welding**

🔧 Applications: **Mobile**

🔧 Issues **Fumes**

COD: GTC1A2200000000



GTC1A22 mobile welding fume extractor with integrated micrometric abatement filtration, for optimum high-pressure fume extraction through two simultaneous welding suction torches or from other applications requiring low-section piping.

Detailed description

High-pressure welding fume extractor with integrated filtration (micrometric reduction 97-98% at 0.3micron) to be connected to max. 2 suction torches of the SAT line, specifically for industrial use in continuous operation (100% duty cycle) thanks to the robust aluminium blower/turbine with three-phase motor of leading brand. The aspirator is designed for operation in manual or automatic mode; in the latter, the aspirator is activated and, by means of a timer, deactivated in synchronisation with the welding cycle.

- The maximum distance, pipe length, between the suction point and the fume production point is 20-25m.
- Ideal solution for one or two welding stations and re-introduction of fumes into the environment (where permitted due to the 98% filtration degree at 0.3 μ in class 10) or directly with expulsion to the outside.
- Automatic activation during arc initiation makes it fully automatic without loss of time.

Construction

- The entire structure is built in a frame with aluminium extrusions and clad with press-folded sheet metal panels and powder-coated
- powder-coated. It guarantees an IP55 degree of protection.
- the pre-filter housing chamber is made of 20/10 sheet metal and of dimensions
- designed to create an air slowing plenum for correct filter passage speed
- Complete with electrical panel for control and protection

Technical characteristics

- Suction from max 2 torches simultaneously
- Power 2200Watt 400/3/50 three-phase
- Max flow rate 240mc/h
- Nominal pressure 250 mbar
- Sound level 72db(A) at 1,5 mt in open field
- Dimensions 490b x 880h x 650d
- Weight 80 kg

Filter section

- Stage 1: Calm prechamber for larger particle abatement
- Stage 2: 99% eff polyester cartridge filtration
- Stage 3: micro-filter panel double seal and protective nets. MPPS efficiency >95%
- Stage 4: Active carbon panel for deodorization



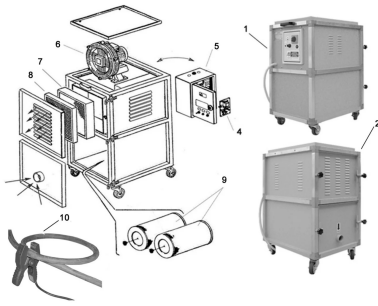

Dimensions

Code	b mm	h mm	P mm
GTC1A2200000000	490	880	650

Technical Data

Code	Power W	Noise Db (A)	Weight kg	Noise level dB	Depression mmH2O	Stage 1 filter	Stage 2 filter	Stage 3 filter	Stage 4 filter
GTC1A2200000000	2200 400/3/50 three-phase	72	80	72 to 1.5 m in free field	250	Calming pre-chamber for the abatement of larger particles	Polyester cartridge filtration eff. 99%	Double gasketed microfilter panel and protection nets. MPPS efficiency > 95%	Activated carbon panel for deodorisation



Photogallery

