



By **GAMMA IMPIANTI s.r.l**
Via Stroppiana n° 15 10071 Borgaro T.se (To) - Italy
Tel. +39 011 4502031 Fax +39 011 4703927
P.IVA IT05898600019
E-mail : info@secureair.it
Web : www.secureair.it

User Manual and Maintenance WFG

Wet collector for dust

CE

MACHINE MODEL	
MACHINE DESCRIPTION	
SERIAL NR.	
MONTH OF CONSTRUCTION	
YEAR OF CONSTRUCTION	
OVERALL WEIGHT	



Index

1.	Foreword.....	4
1.1	Purpose of the manual	4
1.2	Definitions	4
1.3	Confidentiality	5
1.4	Normative references.....	5
1.5	Reporting of errors and discrepancies	5
2.	Safety and safety standards.....	5
2.1	General information.....	5
2.2	General safety rules and instructions	5
3.	Identification of the machine	7
4.	General description.....	7
5.	Noise emission.....	9
6.	Fire risk.....	9
7.	Technical and mechanical characteristics	9
7.1	Performance	11
7.2	Electrical characteristics.....	11
7.3	Electrical Junction Box Connections	15
8.	Optional.....	16
8.1	Electrical resistance(optional)	16
8.2	Dredging conveyor (optional).....	16
8.3	Vent kit for aluminum treatment (optional to be installed on the system)	17
8.4	Atex Certificate Fan.....	19
9.	Designed to use	19
10.	Frequent errors in the use of the machine	19
11.	Residual risk	19
12.	In case of accident or damage	20
13.	Packaging	20
14.	Transport and handling	20
15.	Installation and start-up.....	20
15.1	Positioning	20
15.2	Assembly	20
15.3	Power supply connection	21
15.4	Control of rotation.....	22
16.	Preparation for use.....	22
16.1	Positioning and connections	22
16.2	Procedure for first commissioning of the system.....	22
17.	Utilization	23
18.	Maintenance	23
18.1	Collection tank	23
18.2	Maintenance operations.....	24
18.3	Check and filter cleaning.....	25
18.4	Maintenance of the fan.....	26
18.5	Maintenance of dredging conveyor (optional)	28
19.	Non-ionizing radiation	28
20.	Assembly/Disassembly	29
21.	Search and elimination of system defects	29
22.	Waste disposal.....	30
	Attachment 1 – Maintenance card	31
	Attachment 2 – Error reporting.....	32

1. Foreword

1.1 Purpose of the manual

The "User and Maintenance Manual" describes all the steps necessary for the correct installation and use of the machine with particular care for safety and environmental protection.

This manual must be read with maximum attention before the machinery is brought into operation and kept close to the machinery at the disposal of the user or maintenance staff.

The machine has been designed and built-in compliance with industry safety standards. As evidence of this, the machine has been marked "CE" which ensures compliance with the Machinery Directive.

Any tampering with unauthorised equipment and/or any intervention by non-specialized personnel could impair its proper functioning and even significantly impair its performance.

Additional information not contained in this manual may be requested directly to

Secureair® by GAMMA IMPIANTI S.R.L.

Via Stroppiana n° 15 10071 Borgaro T.se (To) – Italy - Tel. +39 011 4502031 Fax +39 011 4703927
 email: info@secureair.it – website: www.secureair.it

- The information contained in this manual is the property of Secureair® by GAMMA IMPIANTI S.R.L.
- Reproduction, even partial, is prohibited without the prior written consent of Secureair® by GAMMA IMPIANTI S.R.L.
- Secureair® by GAMMA IMPIANTI S.R.L. assumes no liability for any error that may appear in the document and reserves the right to change, without notice, the characteristics of the product in this manual.
- Secureair® by GAMMA IMPIANTI S.R.L. declines all responsibility for any damage suffered by third parties due to incorrect installation, misuse, removal or deactivation of the security devices installed.
- In no case will Secureair® by GAMMA IMPIANTI S.R.L. be liable for any accident or damage to the machine and its components, described in this document, if caused or consequent to the incorrect use of the information contained in the manual.
- Secureair® by GAMMA IMPIANTI S.R.L. assumes that in the plants where the machine was intended, the current safety and hygiene standards are observed.

1.2 Definitions

The terms ATTENTION, WARNING and NOTE are used during the preparation of the manual to highlight instructions or information considered critical or unusual.



	<p>ATTENTION</p> <p>INFORMATION OR PROCEDURE WHICH, IF NOT STRICTLY FOLLOWED, MAY CAUSE INJURY OR DEATH OF PERSONS.</p>
	<p>WARNING</p> <p>INFORMATION OR PROCEDURE WHICH, IF NOT STRICTLY FOLLOWED, MAY CAUSE SERIOUS DAMAGE TO THE MACHINERY OR INDIVIDUAL COMPONENTS.</p>
	<p>Note</p> <p>Information or procedure that can facilitate or simplify maintenance operations, or in any case part of the text of particular importance that you want to highlight.</p>

Figure 1- Manual signs

1.3 Confidentiality

The technical information contained in this manual is the property of Secureair® by GAMMA IMPIANTI S.R.L. and must be considered confidential: therefore, the disclosure and reproduction, even partial, without the written permission of Secureair® by GAMMA IMPIANTI S.R.L.

1.4 Normative references

The purification machine in question in this publication meets the following standards:

Machinery Directive **2006/42/EC**

Low Voltage Directive **2014/35/UE**

Machine safety **EN ISO12100:2010**

Machine safety - **Electrical equipment EN60204-1 machines**

Electromagnetic compatibility **2014/30/UE**

1.5 Reporting of errors and discrepancies

In order to include the most up-to-date information in the manuals, our company analyses the reports received. Operators are invited to report any inaccuracies by sending a message to <http://www.gefextraction.com/it/contatti> or by sending an e-mail to info@gefextraction.com

2. Safety and safety standards

2.1 General information



In order to include the most up-to-date information in the manuals, our company performs an analysis of the reports received. Operators are invited to report any inaccuracies by sending an e-mail to info@gefextraction.com.

2.2 General safety rules and instructions

- ❖ Scrupulously and carefully follow the safety instructions given in this manual.
- ❖ It is recommended to use the personal protective equipment indicated by the relevant regulations.
- ❖ After releasing the product from its packaging, make sure the integrity of this. In case of damage or in case of doubt, contact immediately a professionally qualified person.
- ❖ In case the product has suffered a strong impact or has fallen, proceed to the control of all its parts.
- ❖ If there are structural deformations, or malfunctions, or some component is damaged, you must contact an Authorized Service Center.
- ❖ It's forbidden the installation in an ATEX zone or a zone which could damage the product, if the producer does not allow for this purpose.
- ❖ When using with an air flow rate different from the one indicated, it is necessary to check that the operating level of the water is congruent with the sucked flow rate. If this is not the case, the operating level of the water must be adjusted by acting on an electric level detector placed on a special rod. The operating level must be such that no water escapes from the exhaust stack due to too much water being suspended inside the filter. For higher flow rates the level should be lowered, for lower flow rates the level should be raised. Changes in flow rate and level should be minimal. The minimum level should not be adjusted.
- ❖ Regarding the use of water filters with aluminum, it is necessary to empty the tank frequently and above all according to the workload. This is made necessary by the fact that if the tank is not emptied for a long time, this leads to dissolving the substances present in the various metals or alloys processed in the water, making it able to react with the aluminum powder and making it possible to develop hydrogen and warmth.
- ❖ Use the machine with an ambient temperature (at the engine) between 0# C and +40°C and however with a maximum relative humidity that does not exceed 85%.
- ❖ The machinery and the surrounding area must be free of hazardous deposits and materials in general, if the environmental characteristics for which the machinery is intended to operate are modified, the manufacturer is not responsible for any malfunction or for any risk or damage that may occur.
- ❖ Before any maintenance or cleaning activities switch off the machine. Make sure that the main power has been disconnected and it can't be switched on for any reason (incidental also).
- ❖ The use of any electrical equipment involves compliance with certain basic rules, including:

Must not be touched with wet or wet hands;
 It must not be touched barefoot.

- ❖ Adhesive labels, which indicate a possible danger or recommendation for use, must not be removed.
- ❖ The machinery must be periodically checked as indicated in the owner's manual.
- ❖ The machinery must be used only by persons authorized and trained for the purpose; the same precaution applies to persons required to carry out maintenance. When performing maintenance, adopt all possible safety regulations, precautions and all the measures and procedures indicated for individual operations; during maintenance, require any person present as a staff member to take the necessary security measures.
- ❖ The machine, or its components, must not be modified without the prior written permission of Secureair® by GAMMA IMPIANTI S.R.L. If changes are made to the machine and its components, without the prior written permission of Secureair® by GAMMA IMPIANTI S.R.L. any form of guarantee will lapse. Secureair® by GAMMA IMPIANTI S.R.L. is not liable for any malfunctioning of the machine, damage to property or persons if unauthorized operations are carried out.
- ❖ Secureair® by GAMMA IMPIANTI S.R.L. S.r.l. is not responsible for any use other than that for which the machine was designed. For the use of the machine in the manual see the chapter "Intended use".
- ❖ Ensure that all protections and repairs are properly secured; in case they are damaged, proceed to their immediate replacement and repair. Do not approach unprotected equipment and do not remove guards when the electrical circuits are under voltage.
- ❖ At the end of the maintenance and/or repair operations, before reconnecting the machine to the electrical grid, the person responsible for the work must ensure that the repairs and safety devices are correctly installed.
- ❖ Wear suitable personal clothing and protective equipment during cleaning and maintenance.
- ❖ Do not perform operations on the machine when it is running and without verifying that the machine is disconnected from the power grid.
- ❖ Use equipment and instruments of the approved type.
- ❖ Verify that the safety devices fitted to the machine, or parts thereof, are maintained in perfect working order
- ❖ Use only suitable and up-to-date devices for handling the machine;
- ❖ Do not attach the machine to any other foreign matter.
- ❖ Do not place any tools and/or objects on the machine.
- ❖ Do not introduce extraneous or sharp objects of any kind which may cause damage or obstruction of the filter section, nor smoke near the suction hoods.
- ❖ The Safety Officer shall ensure that the personnel responsible for the use of the machinery have read and understood this manual in its entirety.
- ❖ It remains the responsibility of the head of the company's security to verify the state of risk of the company according to D.Lgs. 81/08

	<p>REMOVE TENSION BEFORE ANY ORDINARY OR EXTRAORDINARY MAINTENANCE OF THE MACHINERY; ALL OPERATIONS MUST BE CARRIED OUT WITH MACHINERY PLACED IN A SAFE POSITION.</p> <p>CONTACT OF THE BODY WITH ELECTRIC CONDUCTORS NOT ADEQUATELY INSULATED OR PROTECTED MAY BE FATAL. ONLY QUALIFIED PERSONNEL SHALL BE AUTHORISED TO CARRY OUT WORK ON ELECTRICAL EQUIPMENT AND COMPONENTS. DURING MAINTENANCE, CAREFULLY INSULATE AND SECURE FROM THE POWER SUPPLY THE CIRCUITS AND APPARATUS ON WHICH ACTION IS TO BE TAKEN.</p>
	<p>VERIFY THAT THE APPARATUS IS INSTALLED AND USED IN ACCORDANCE WITH LOCAL LAWS AND REGULATIONS.</p>
	<p>The company Secureair® by GAMMA IMPIANTI S.r.l. assumes no responsibility in the event of accidents resulting from improper use of the product in question and in particular in the following conditions:</p> <ul style="list-style-type: none"> - REMOVAL or modification of safety devices; - use of equipment not complying with Secureair® by GAMMA IMPIANTI S.r.l.; - modification of the apparatus without prior authorization from Secureair® by GAMMA IMPIANTI s.r.l.; - use of accessories and spare parts not supplied by GAMMA IMPIANTI S.r.l. if not authorized; - use of the apparatus for purposes other than those for which it was intended.

3. Identification of the machine

The machine is identified by the CE plate fixed in solidarity with the structure.
 The plate shall contain the following information:

- ❖ Manufacturer's logo
- ❖ Machine model
- ❖ Freshman
- ❖ Feeding
- ❖ Amperage
- ❖ Year of construction
- ❖ Overall weight

4. General description

The WFG water dust treatment plant consists of an intake chamber, a settling tank with an inertial separator, a droplet separator and a suction unit connected to the evacuation section of the treated air.

The structure of the filtering unit is made of sheet metal first choice punched with punching machine controlled and folded with bending machine 6 axes. The panels are coupled with electric welding or bolted in order to form a single self-supporting body. The filter structure is painted with epoxy powder paint.

The air flow to be purified takes place on the upper side of the filter due to the depression created by the fan inside the filter structure.

Through special shaping, the flow follows a path that causes the dust to deposit on the water and sediment in it. In addition, the dusty air is mixed with water. This event leads to the formation of micro drops of water containing dust.

Continuing the air flow it is obliged to follow a specially realized path that through the centrifugal force leads to the separation of the dirty drops from the air.

Before reaching the suction unit, the flow passes through a droplet separator composed of fins made of galvanized sheet metal mechanically fixed to the flanged frame equipped with holes for draining water.

The vacuum cleaner is placed inside the filter structure. If required, only the vacuum cleaner can be supplied in ATEX version.

The treated air ejection line shall be connected to the top of the filter to the appropriate flange.

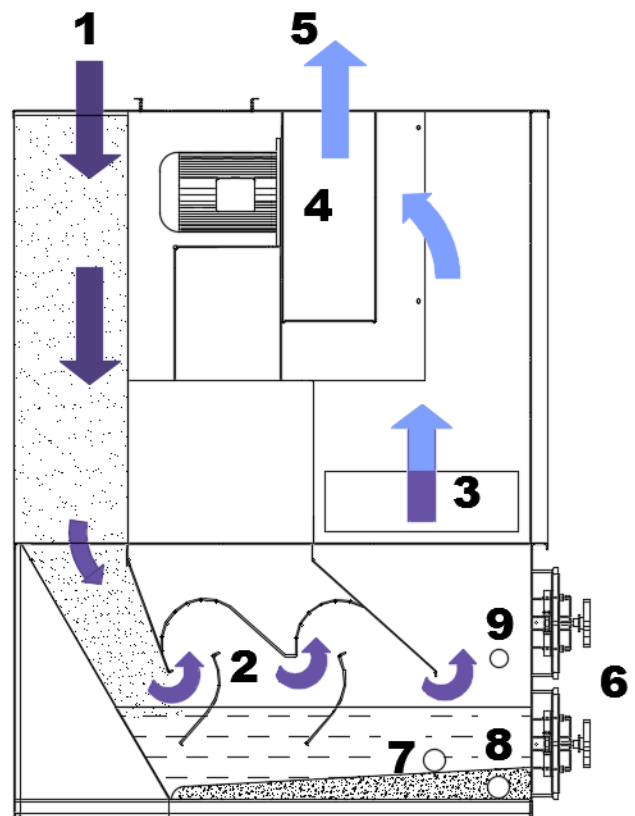
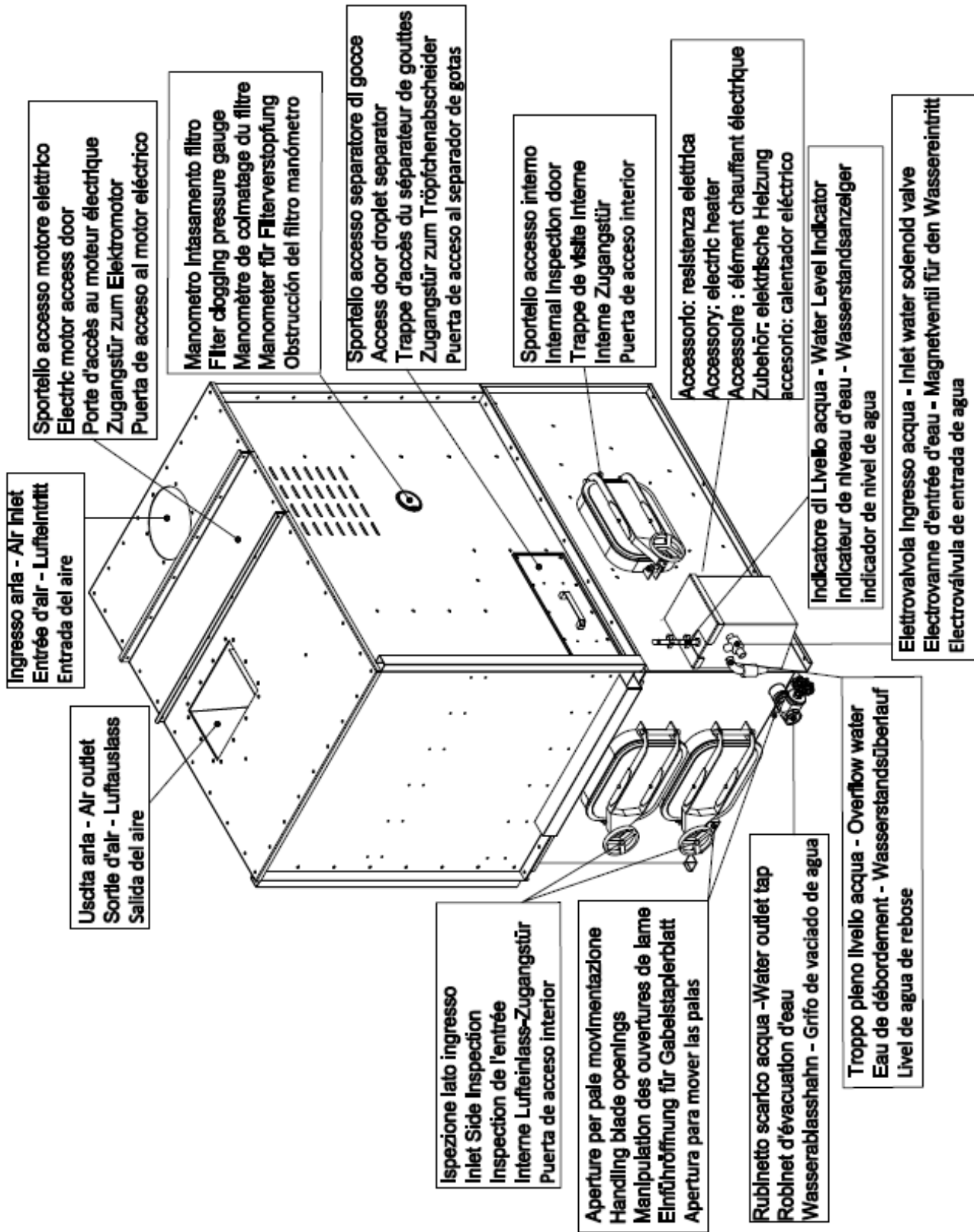

Figure 2 - Scheme of operation WFG

- | | |
|-----------------------|------------------------------------|
| 1. Dust air inlet | 6. Inspection door |
| 2. Inertial separator | 7. Preparation for heating element |
| 3. Droplet separator | 8. Tank discharge |
| 4. Fan | 9. Overflow |
| 5. Outlet | |



5. Noise emission



A source of noise consists of the air flows from the collection devices and the suction unit installed inside the filter: in order to limit the noise to the outside of the entire system, the speeds of these flows are as low as possible, consistent with the need to ensure filtration efficiency and avoid the possible deposition of substances carried. The vacuum chamber is also covered with sound-absorbing material to attenuate the noise emission to the outside produced by the electric fan.

6. Fire risk

The tank containing the water has the dual purpose of filtering the solid particles present in the flow and to cool the incandescent particles.

Where the working processes do not make it possible to rule out this circumstance, further measures should be taken to detect the presence of any sparks or to adopt suitable alternative devices.

Due to the variety of types and chemical composition of the dust that are vacuumed, chemical reactions can be generated inside the tank so it is recommended to empty the tank frequently (par.18.3) and install the vent kit to reduce the percentage of any gases inside the purifier.

	ATTENTION DO NOT USE THE MACHINE IN OPERATIONS WHICH PRODUCE OPEN FLAMES OR IN THE IMMEDIATE VICINITY OF OPEN FLAMES.
	ATTENTION DO NOT APPROACH WITH OPEN FLAMES, INCANDESCENT OR SIMILAR BODIES IN THE IMMEDIATE VICINITY OF THE PURIFIER.
	ATTENTION DO NOT INSERT LIQUIDS OTHER THAN WATER INTO THE TANK. DO NOT USE MACHINERY TO VACUUM LIQUIDS OR OTHER SUBSTANCES WHICH ARE POTENTIALLY FLAMMABLE AND MAY OCCUR.

7. Technical and mechanical characteristics

Model	A*	B	H	Ø c –c x d [inlet]	a x b [outlet] **	empty weight [Kg]	Approximate water volume [Litr]	Size Droplet separator [mm]
								H=140mm
WFG 1	900	1.560	2.250	180	185x130	680	230	790x460
WFG 2	900	1.800	2.250	250	320x230	810	270	790x595
WFG 3	1.500	1.800	2.250	300	400x290	1100	450	1095x595
WFG 4	1.900	1.800	2.250	450x220	450x320	1200	460	1495x595
WFG 5	2.300	1.800	2.250	650x220	360x510	1350	570	790x595 + 1095x595
WFG 6	2.300	1.800	2.700	850x220	Nr.2 - 361x256	1600	550	790x595 + 1095x595

*If the dredger is installed the overall dimensions are subject to a change. See paragraph 8 or refer to the offer

** the dimensions indicated refer to the standard product. The purifier may have installed a different aspirator from the standard one on the customer's request.

Table 1 - Dimensions of WFG models

Model	Mod. Fan	Flow [m³/h]	Total pressure [Pa]	Residual prevalence [Pa]	Noise [Db(A)]	Data of the fan*			
						Power [kW]	Volt [V] Trifase	Ampere [A]	Electric cable [mm²]
WFG 1	VM450R/ 2 3KW	1.500 2.000	2.730 2.240	2.230 1.740	85	3	400/230	5.9	4 x 2.5
WFG 2	RM400/2 4KW	2.000 4.000	2.740 2.090	2.240 1.590	88	4	400/230	7.7	4 x 2.5
WFG 3	GF450R/ 2 5.5KW	4.000 6.000	2.690 2.090	2.190 1.590	90	5.5	400/230	10.5	4 x 4
WFG 4	RH450/2 B 7.5KW	6.000 8.000	2.800 2.490	2.300 1.990	91	7.5	400/230	14.2	4 x 4
WFG 5	GF500/2 11KW	8.000 10.000	3.170 2.540	2.670 2.040	92	11	400/230	20.2	4 x 6
WFG 6	Nr2 GF450/2 7.5KW	10.000 12.000	2.820 2.550	2.320 2.050	92	7.5x2	400/230	27.4	4 x 6

If there are accessories, please check the features in the appropriate paragraphs

*If required, the vacuum cleaner can be supplied with an electric motor in the ATEX version and/or with an anti-beltting mouthpiece; the adoption of these devices does not allow its installation in ATEX certified areas or for explosive products.

Table 2 - Performance and characteristics

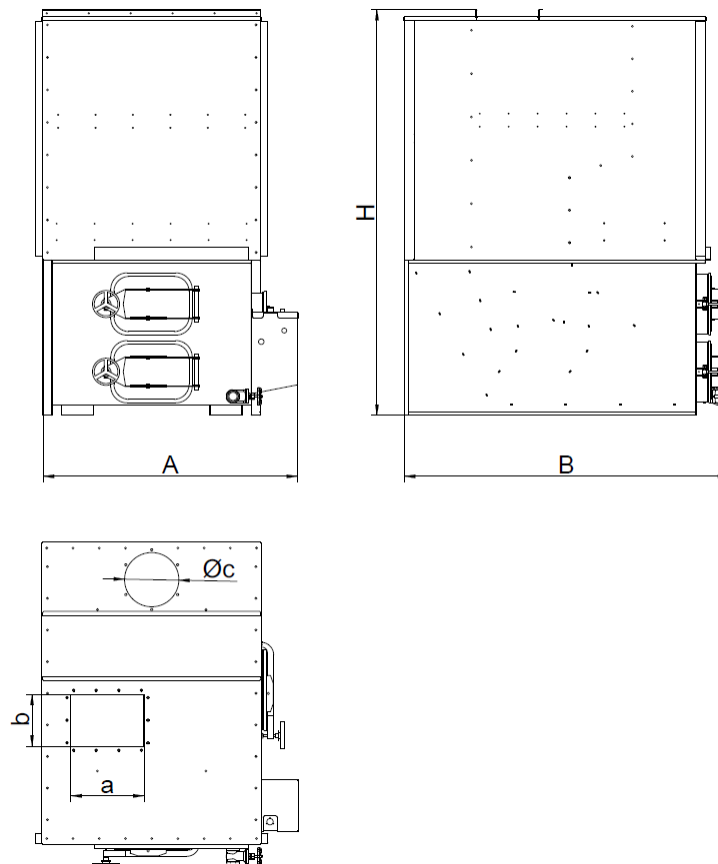

Figure 4 - Reference

7.1 Performance

Performance is measured with calibrated instruments and periodically certified by external laboratories.
 For machine performance see Cap.7 tab. 2.

7.2 Electrical characteristics

The purifiers are designed to be supplied with 230/400V-50hz Three-phase mains voltage.



	<p>DISCONNECT FROM THE POWER GRID BEFORE ANY INTERVENTION</p>	
	<p>If the mains voltage is 230V at 50hz three-phase you need to intervene on the terminal block of the electric motor of the fan by changing the position of the mounts as shown in the figure next to it. Only qualified personnel are allowed to perform interventions on electrical systems and components.</p>	<p>Collegamento dei cavi elettrici su motore elettrico Connection of electric cables on electric motor Raccordement des câbles électriques sur moteur électrique</p> <div style="display: flex; justify-content: space-around;"> <div data-bbox="715 835 1013 1227"> <p>230V/3Ph/50Hz</p>  </div> <div data-bbox="1161 835 1460 1227"> <p>400V/3Ph/50Hz</p>  </div> </div>

Table 3 - Electrical characteristics

For the size of the power cord see Table 2.
 Electrical characteristics of the engine: see table 2.

The level indicator, located outside the filter, uses three bistable sensors to control the levels required for the filter to function properly. On the side is a schematic drawing of the level indicator.

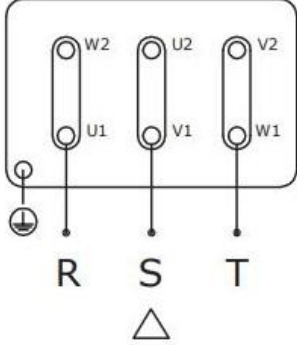
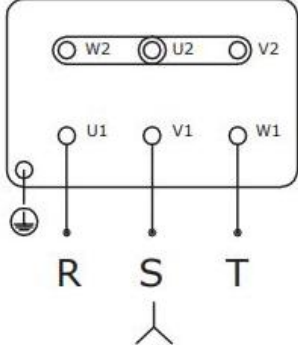
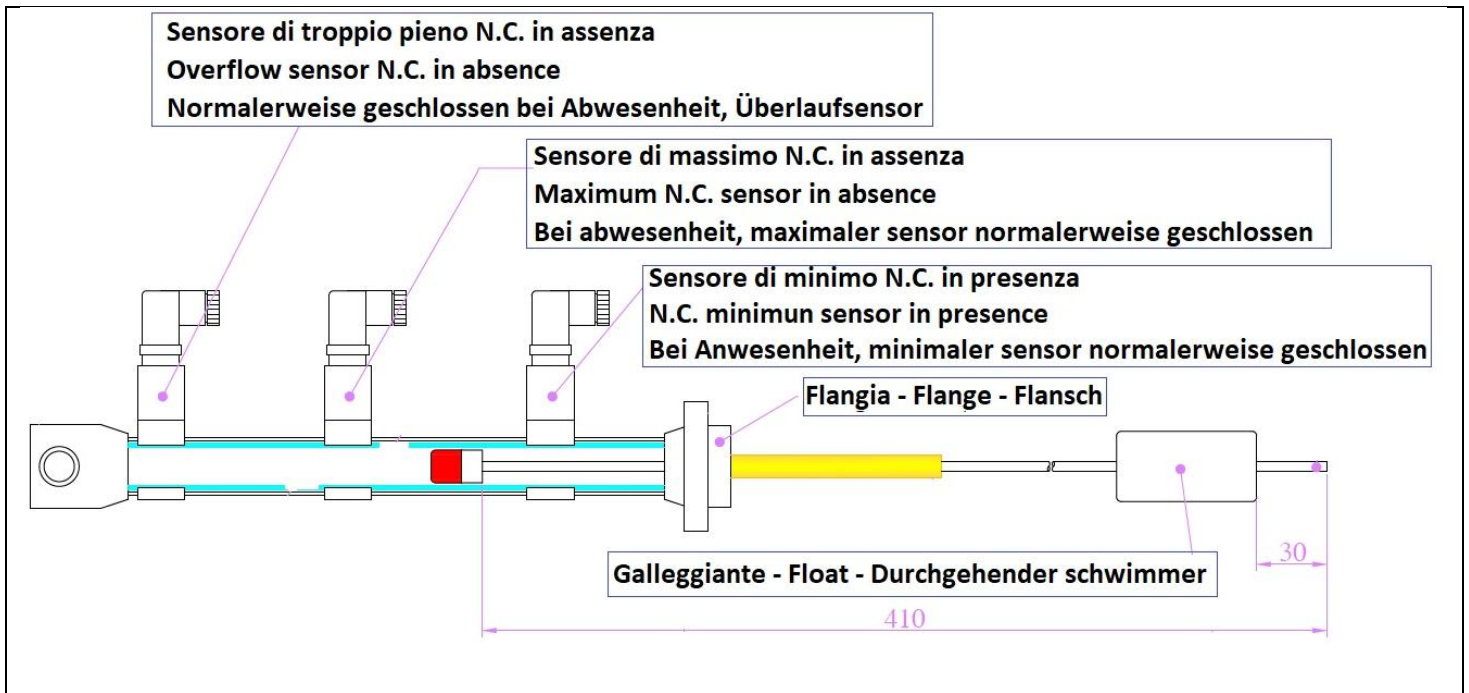

WATER SERVICE LEVEL

Water level for normal filter operation.

If the water level falls below the set value, an open command is sent to the solenoid valve of the water supply valve. When the correct level is reached, the solenoid valve receives a closing signal.

The level management is done with the Hoover switched off and with the main switch of the panel on ON, because with the Hoover switched on the water level is higher than with the Hoover switched off

MINIMUM WATER LEVEL

If the water level drops below the value set by the appropriate sensor, a signal is sent to switch off the pool Hoover and the corresponding indicator light on the control panel is on.

Check the water supply and wait for the water level to return to the maintenance level.

Once the level is restored, press start to switch on the fan.







WATER OVERFLOW LEVEL



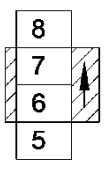
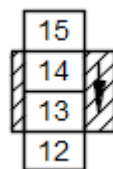
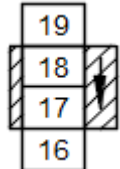
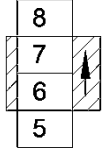
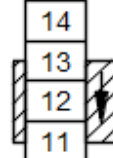
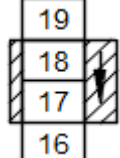
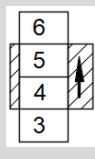

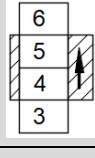
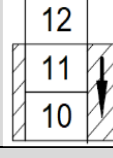
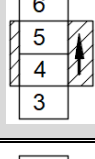
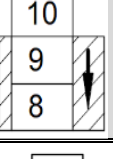
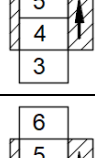
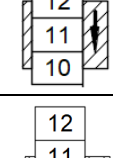
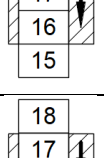
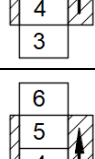
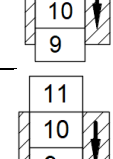
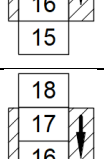
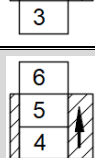
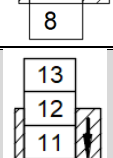
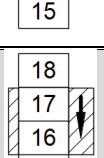





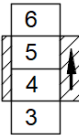
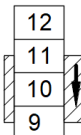

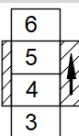
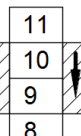
If the water level rises to the value set with the appropriate sensor, a signal is sent to switch off the vacuum pool cleaner and the relevant warning light on the control panel comes on.

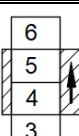
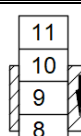
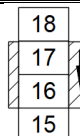
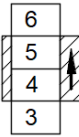
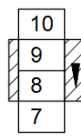
Restore the operating level of the filter by opening the water overflow tap in the appropriate container and then the 2" tap to reach below the operating level so that the water inlet solenoid valve restores the correct level.

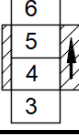
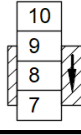
Before using the filter again, research and solve the problem that led to the high water level. One of the possible causes could be a malfunction of the water supply solenoid valve.

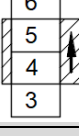
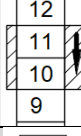
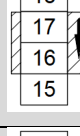
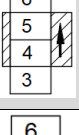
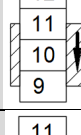
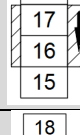
Once operation has been restored, press start to switch on the fan.

Mod.	Fan	Flow [m³/h]	Minimum water level	Maintaining water level	Water overflow level
WFG 1 con lama 12cm+5cm	VM450 3KW	1.500	liv.7.5 6-8 	liv.14.5 13-15 	liv. 17.5 17-19 
WFG 1 con lama 12cm+5cm		2.000	liv.7.5 6-8 	liv.13 11.5-13.5 	liv. 17.5 17-19 
WFG 2	RM400/2R 4KW	2.000	liv.5.5 4-6 	liv. 13 11.5-13.5 	liv. 17.5 17-18
WFG 2		3.000	liv.5.5 4-6 	liv.11.5 10-12 	liv. 17.5 17-18
WFG 2		4.000	liv.5.5 4-6 	liv.9.5 8-10 	liv. 17.5 17-18
WFG 3 con lama 7.5cm	GF450R/2 5.5KW	4.000	liv.5.5 4-6 	liv.13 11.5-13.5 	liv. 17 16-18 
WFG 3 con lama 7.5cm		5.000	liv.5.5 4-6 	liv.11.5 10-12 	liv. 17 16-18 
WFG 3 con lama 7.5cm		6.000	liv.5.5 4-6 	liv.13 8-10 	liv. 17 16-18 
WFG 4	RH450/2 B 7.5KW	6.000	liv.5.5 4-6 	liv.10.5 9-12.5 	liv. 17 16-18 

WFG 4		7.000	liv.5.5 4-6 	liv.10 8.5-11.5 	liv. 17 16-18 
WFG 4		8.000	liv.5.5 4-6 	liv.9.5 8-11 	liv. 17 16-18 
WFG 5	GF500/2 11KW	8.000	liv.5.5 4-6 	liv.10 8.5-10.5 	liv. 17 16-18 
WFG 5		9.000	liv.5.5 4-6 	liv.9.5 8-10 	liv. 17 16-18 
WFG 5		10.000	liv.5.5 4-6 	liv.9 7.5-9.5 	liv. 17 16-18 
WFG 6	Nr2 GF450/2 7.5KW	10.000	liv.5.5 4-6 	liv.11.5 10-12 	liv. 17 16-18 
WFG 6		11.000	liv.5.5 4-6 	liv.11 9.5-11.5 	liv. 17 16-18 
WFG 6		12.000	liv.5.5 4-6 	liv.10.5 9-11 	liv. 17 16-18 

7.3 Electrical Junction Box Connections

Collegamenti elettrici - Electrical connections
 Connexions électriques - Elektrische Anschlüsse
 Conexiones eléctricas

ALIMENTAZIONE VENTILATORE MAX 11kW FAN POWER SUPPLY MAX 11kW ALIMENTATION DU VENTILATEUR MAX 11kW LÜFTERSTROMVERSORGUNG MAX 11kW ALIMENTACION VENTILADOR MAX 11kW	PE \perp
	U01 -30U.1
	V01 -30V.1
	W01 -30W1
PROTEZIONE TERMICA MOTORE ELETTRICO ELECTRIC MOTOR THERMAL PROTECTION PROTECTION THERMIQUE DU MOTEUR ÉLECTRIQUE THERMISCHER SCHUTZ VON ELEKTROMOTOREN PROTECCION TERMICA DEL MOTOR ELECTRICO	T1
	T2
PROTEZIONE TERMICA MOTORE ELETTRICO ELECTRIC MOTOR THERMAL PROTECTION PROTECTION THERMIQUE DU MOTEUR ÉLECTRIQUE THERMISCHER SCHUTZ VON ELEKTROMOTOREN PROTECCION TERMICA DEL MOTOR ELECTRICO	T1
	T2
RESISTENZA ELETTRICA 2.5kW ELECTRICAL RESISTANCE 2.5kW RESISTANCE ELECTRIQUE 2.5kW ELEKTRISCHER WIDERSTAND 2,5 kW RESISTENCIA ELECTRICA 2.5KW	UR01
	VR01
	WR01
	PE \perp
ELETTOVALVOLA INGRESSO ACQUA WATER INLET SOLENOID VALVE ÉLECTROVANNE D'ENTRÉE D'EAU WASSERZULAUF-MAGNETVENTIL ELECTROVALVULA DE ENTRADA DE ACQUA	0 - 50.4
	6 - 0L24
SENSORE MANTENIMENTO LIVELLO ACQUA WATER LEVEL MAINTENANCE SENSOR CAPTEUR DE MAINTIEN DU NIVEAU D'EAU SENSOR FÜR DIE WASSERSTANDSERHALTUNG SENSOR DE MANTENIMIENTO DEL NIVEL DE AGUA	241 - 1L24
	1 - 50.3
SENSORE LIVELLO MINIMO ACQUA MINIMUM WATER LEVEL SENSOR CAPTEUR DE NIVEAU D'EAU MINIMUM MINDESTWASSERSTANDSSENSOR SENSOR DE NIVEL MINIMO DE AGUA	241 - 1L24
	2 - 50.1
SENSORE LIVELLO TROPPO PIENO OVERFLOW LEVEL SENSOR CAPTEUR DE NIVEAU DE DÉBORDEMENT ÜBERLAUFPEGELSENSOR SENSOR DE NIVEL DE DESBORDAMIENTO	241-1.L24
	3 - 50.5
	PE \perp
SONDA TEMPERATURA - TEMPERATURE SENSOR SONDE DE TEMPÉRATURE - TEMPERATURMESSFÜHLER - SONDA DE TEMPERATURA	4
	5

PTC Only available on 7.5kW and 11kW fans.

Electric heater and temperature probe only present on models with related accessories

8. Optional

8.1 Electrical resistance(optional)

If required, the WFG filter can be equipped with an electrical resistance that prevents the filter from working with frozen water. The electrical resistance is coupled to a probe that monitors the temperature inside the tank; if the freezing temperature of 0 ° C is reached. The activation of the electrical resistance, located on the bottom of the tank, involves the simultaneous shutdown of the aspirator to which it is connected as the devices are powered by the same electrical panel supplied with the filter as long as the electrical resistance is in operation, the aspirator cannot be put back into operation because frozen water would prevent the filter from working properly. Once a safety temperature has been reached, the electrical resistance switches off and it is possible to manually restart the aspirator.

The electrical resistance has the following technical specifications:

Mod.	Caratteristiche di resistenza elettrica		Features of electrical resistance		Spécifications de résistance électrique	
	Tensione trifase [V]	Potenza [V]	three-phase voltage [V]	power [kW]	Tension triphasée [V]	Tension triphasée [V]
WFG 1	400	2,5	400	2,5	400	2,5
WFG 2	400	2,5	400	2,5	400	2,5
WFG 3	400	2,5	400	2,5	400	2,5
WFG 4	400	2,5	400	2,5	400	2,5
WFG 5	400	2,5	400 </td <td>2,5</td> <td>400</td> <td>2,5</td>	2,5	400	2,5
WFG 6	400	2,5	400	2,5	400	2,5

Table 4 - Specifications of electrical resistance

8.2 Dredging conveyor (optional)

The dredging conveyor allows to remove in a continuous way the deposits of heavy dust that otherwise would end up depositing on the bottom of the filter. The device is equipped with metal profiles, called "porters", which allow you to bring the chips to the end of the conveyor where they fall freely in a special container (not included in the supply of the filter). The movement of the steel scraper blades is determined by two side chains powered by a worm-worm worm motor with self-ventilated three-phase asynchronous motor 0.37kw placed in the end of the machine.

The dredging conveyor is designed, built and protected for the removal of shredded shavings. The device does not comply with the treatment of products of a particle size other than that specified at the offer stage or for the treatment of products with flammability characteristics and/or within explosive atmospheres.

The device is powered by the electrical panel on board the filter and allows you to manage the operation of the machine. By means of the controls installed on the electric panel of the filter, the operation of the dredging system can take place either continuously or at a time when the aspirator is switched off.

Although both operating configurations are available, it is strongly recommended to operate the device continuously in order to avoid an excessive deposit of material on the porters placed in the submerged part of the filter and therefore reduce the stresses to which the electric motor of the electric motor can be subjected when this is started.

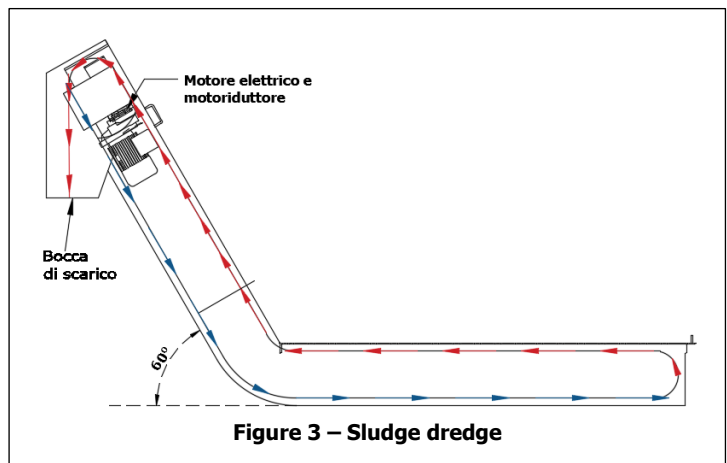

It is essential that the water reintegration system remains open to maintain the stability of the filter and thus ensure its functionality.

In case of long machine downtimes, it is very important to avoid the creation and compaction of material deposits by keeping active for long periods of time to ensure that all the material that has deposited on the bottom of the filter is completely removed by means of maintenance of the conveyor in order to avoid excessive sedimentation of material which can seriously damage the machine.

With the installation of the dredge the filter undergoes a change in dimensions

8.3 Vent kit for aluminum treatment (optional to be installed on the system)

Regarding the use of water filters on grinders or for similar processes, it should be noted that in case of use with aluminum it is necessary to empty the tank frequently and above all according to the workloads. This is made necessary by the fact that if the tank is not emptied for a long time, this leads to dissolving the substances present in the various metals or alloys processed in the water making it able to react with the aluminum powder and making it possible to develop hydrogen. and warmth.

The vent kit serves to reduce the % of hydrogen inside the purifier.

This kit must be installed on the suction line arriving at the filter. The kit consists of a branch equipped with two dampers, one connected to the suction line and one that functions as a "false air" intake. When the machine tool is turned on, the valve will move to "false air" making the fan work with clean air for a few minutes (based on the workloads). After this time, the diverter valve will move to the suction line of the system, sucking on the connected suction points.

On the electrical panel there is a warning light to signal to the operator that the suction line is not working. The operator will therefore know that for a few minutes (based on the workloads) the machine tool will not be able to work.

	DISCONNECT FROM THE MAINS BEFORE SERVICING
	THE INSTALLATION POSITION OF THE BREATHER KIT MUST BE SUCH THAT THE FALSE AIR INTAKE CAN DRAW IN AIR FREE OF DUST AND GAS.
	THE INSTALLATION POSITION OF THE BREATHER KIT MUST BE SUCH THAT THE FALSE AIR INTAKE CANNOT DRAW IN AIR WITH SPARKS, INCANDESCENT PARTICLES, OPEN FLAMES.
	DO NOT INSTALL THE APPLIANCE IN PLACES WITH EXPLOSIVE ATMOSPHERE OR FLAMMABLE ATMOSPHERE OR IN PLACES CERTIFIED BY THE ATEX

**INSTALLAZIONE ORIZZONTALE - HORIZONTAL INSTALLATION
 INSTALLATION HORIZONTALE - INSTALACIÓN HORIZONTAL -
 HORIZONTALE INSTALLATION**

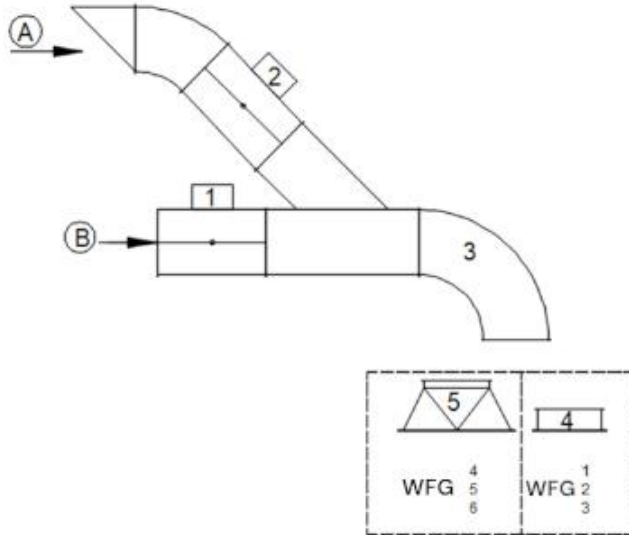

Operating logic of the ventilation kit

Situation with main switch OFF: dampers 1 and 2 closed.

Main switch ON: flaps 1 and 2 closed.

The fan is switched on by push button on the control panel or by remote control:

Damper 2 opens and the fan starts with a slow ramp or delayed start compared to the opening of damper 2 (because everything is closed).

If the minimum float level is in the right position and the temperature sensor reads the right value, damper 1 opens and when it is fully open, damper 2 closes.

When damper 2 closes, an indicator light (or the consent of the remote control) will come on, indicating that the operating machine can be used.

Stopping the fan by push button on the panel or by remote control:

both flaps close with a delay in relation to the fan to avoid sucking in the filter.

**INSTALLAZIONE VERTICALE - VERTICAL INSTALLATION
 INSTALLATION VERTICALE - INSTALACIÓN VERTICAL - VERTIKALE
 INSTALLATION**

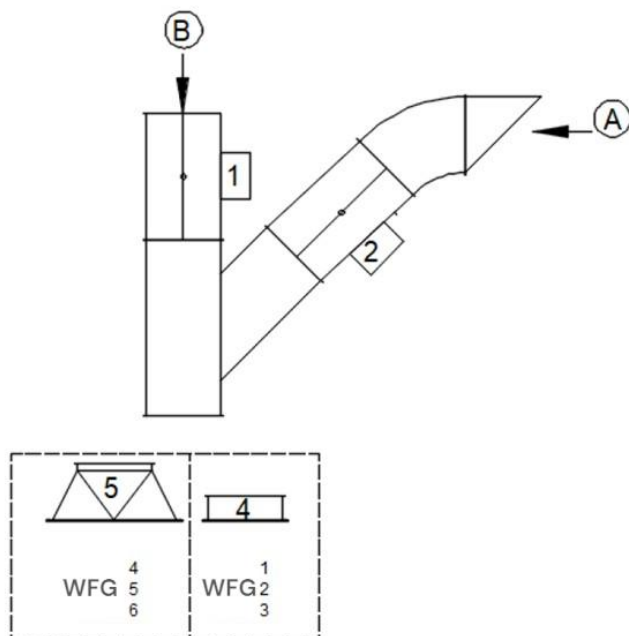

Legend:

A= False air inlet. Terminal equipped with anti-intrusion net.

B= Connection to the suction line.

C= Connection to the filter inlet.

1= Electrical register of the suction line.

2= Electrical false air inlet damper.

3= 90° bend for horizontal installation only

4= Coupling sleeve for mounting on models WFG 1 – 2 – 3

5= Section change to be mounted on models WFG 4– 5 - 6

8.4 Atex Certificated Fan

Atex certified fan can be installed inside the purifier. Please refer to the specific manual.

9. Designed to use

The machine is designed and built for the extraction and filtration of dry dusts resulting from industrial machining of metal products. The system must not be used in operating conditions other than those foreseen during design.

This machine is only and exclusively intended to be used when the sucked product:

Is not soluble in water, does not float in water, is not an aggregating powder and for all situations in which the powder does not precipitate at the bottom of the filter.

Check that the dust being drawn in does not give rise to reactions that could result in the production of gases harmful to health and the environment.

Do not use the filter to treat any type of liquid or vapour; the filter is not designed for this type of application.

The machine cannot be installed in ATEX classified areas.

In particular, the machine is manufactured and intended for the processing for which it was requested and for which the specifications were indicated at the offer stage; its acceptance implies confirmation of the intended use. In case of incorrect use or if the type of machining for which the machine is intended is not specified, Secureair® by GAMMA IMPIANTI S.R.L. declines all responsibility in case of malfunction or accident.

The machine is designed and built for the extraction and filtration of dry powders resulting from industrial processing on metal products. The installation shall not be used under operating conditions other than those foreseen during the design.



ANY OTHER OPERATION OR PROCESS, OTHER THAN THAT IN RESPECT OF WHICH THE FILTER IS DESIGNED, NEAR THE INTAKE POINTS SHALL BE PROHIBITED AS IT MAY CAUSE DAMAGE TO OR FIRE RISKS.

10. Frequent errors in the use of the machine

Do not use the filter to treat any type of liquids or vapours; the filter is not designed for this type of applications.

Do not use the filter to filter dust other than that for which the filter is suitable, even if of similar particle sizes.

Do not use the filter for suction rates other than those for which it has been designed.

Verify correct direction of rotation of the vacuum cleaner.

Correct supply voltage of the aspirator.

Do not insert liquids other than water inside the tank.

Verify the presence of water that must have the right level.

Check the connection with water supply.

Do not throw cigarette butts inside the filter or other material for which the filter has not been designed.

11. Residual risk

In case of filter fire proceed to the call for fire brigade intervention, remove the current and move away from the filter. In case of gas exhalations inside the tank, turn off the intake. Do not approach the filter with open flames or bodies that may produce sparks or electrical contacts, proceed to the emptying in tanks of the liquid contained by running water inside the tank in order to increase the dilution of the dust present in the liquid. Check that the gas produced does not enter the company through the intake channels, close any suction points. Secure the area of the filter and collection tanks. Check the evolution of the phenomenon until its end.

During maintenance care should be taken not to forget objects above the filter because there is a risk that they fall and injure people or damage equipment.

Do not remove protections from electrical parts while they are under voltage due to the risk of electrocution.

Do not enter inside the filter to replace, view or clean without being equipped with appropriate protection from any gas or debris present in the filter and without a specific authorization from your manager.

12. In case of accident or damage

Stop the fan and turn off the power, call 118 if necessary or otherwise stick to what the corporate safety procedure.

13. Packaging

The machine is supplied assembled, covered with transparent film and placed on pallets.

14. Transport and handling

For transport follow the following directions:

- Do not overlay packaging material;
- Do not expose the material to atmospheric agents;
- Suitable means of handling shall be used;
- Carry the filter without water inside the tank.



**ATTENTION:
FOR HANDLING THE COLLECTOR USE PROPER TOOLS AS CURRENT REGULATION**

15. Installation and start-up

15.1 Positioning

The positioning zone must be accessible for any cleaning, maintenance and repair work, and must be levelled and in any case able to withstand a distributed and concentrated load suitable for the installed machine.

The machine must be positioned taking into account that three sides of the machine must be left free for connections with the reintegrating water, with the water discharge pipe and overflow, with the electric line and free access to the various inspection doors cleaning tank and separator drops.

In the immediate vicinity of the machine, in a position agreed with the manufacturer, the electric power supply for the 230/400V three-phase aspirator must be provided at the customer's expense.

This machine is made using electrical components and accessories in order to ensure a degree of protection against the penetration of solid and liquid bodies IP 55, and therefore to comply with the installation conditions required by CEI 64-8 and CEI 64-2, it can be used in environments:

- ordinary
- damp or wet
- at increased risk in the event of fire
- class 3 zone 2 (C3Z2)
- class 1 buffer zone (C1ZR).

The machinery must be fixed to the ground.



The purifier is supplied with special brackets for fixing to the ground, it must be verified that they can be used on the base on which the purifier is placed.

This machine cannot be placed in places classified ATEX.

15.2 Assembly

The machine is supplied assembled. The machine must be handled exclusively through the use of a forklift using the holes placed at the bottom of the filter.

15.3 Power supply connection

	ATTENTION ALL OPERATIONS ABOUT THE CONNECTION OF COLLECTOR TO THE MAINS AND STARTING MUST BE MADE BY A SPECIALIZED PERSONNEL.
	ATTENTION THE MAIN MUST BE PROTECTED AGAINST ANY INDIRECT IEC 204-1
	WARNING BEFORE CONNECTING THE MACHINE TO THE MAIN, VERIFY THAT POWER SUPPLY IS 400 V / 50 Hz THREE PHASE. FOR OTHER CASE FOLLOW THE INSTRUCTIONS CONTAINED IN THE "WARNING" SECTION 5.2

The machine is supplied with an external electrical box for connecting the power supply to the aspirator.

The machine is supplied with an electrical panel not on board the filter.

The electrical panel must be connected to the power supply of the input line, to the extractor power box and to any accessories such as electric minimum and water supply sensors, thermal probe, electrical resistance, vent kit, sludge dredger.

Machine with fan and control panel

The machine is at the time of its complete installation of all the electrical system necessary for its operation, including the thermal and magnetic protections of the various elements present within the framework.

Inside the panel, once the plug has been disconnected, the hatch is opened and the power terminal block is accessed, provided for connecting the input line, marked by the initials L1-L2-L3, and the protection cover bearing the symbol



as well as the terminal for connecting the track-side assembly with the yellow-green colour, the words PE and



the symbol

The terminals for the motor power line and its grounding are provided for conductors as shown in the table 2

Once the connections have been made, taking care to tighten the terminals well, all the present protections must be restored and verified that the installed conductors do not present any damage to their insulation or active parts discovered.

The supply line of the machine control panel must be dimensioned and protected so as to ensure both the operation in case of departure of the engine (starting point) protection against indirect contacts coordinated with the value of resistance of the present ground dispersion system, and therefore a power supply with a section pipe of at least 6 mm² protected by a differential magneto thermic device with a calibration of 3 x 32 A I_{dn} = 0,03. It shall also be ensured that the overall voltage drop with the machinery in operation ensures at least a voltage of 375 V.

Once the power line is connected, before putting the machine into service, in order to ensure the correct operation of the entire system, you will have to check the right direction of rotation of the engine.

For more information see the electrical diagram of the electrical panel.

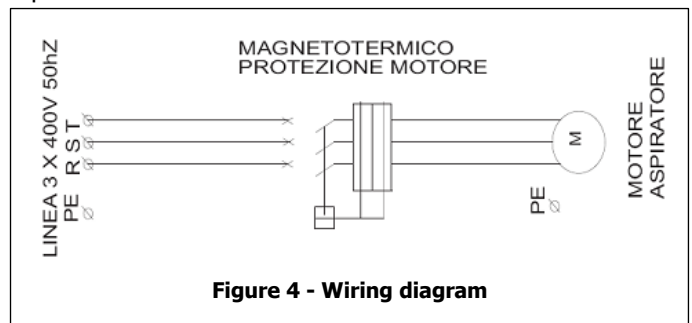

	MACHINERY MUST BE PROVIDED WITH A RUNNING BUTTON AND A STOP BUTTON FOR NORMAL OPERATION.
---	---

15.4 Control of rotation

The filter is equipped with an electric junction box which shows the connections to be followed to connect properly the cables coming from the switchboard in order to obtain the correct direction of rotation of the vacuum cleaner.

16. Preparation for use

16.1 Positioning and connections

Preparation for use of the purifier consists essentially of:

- ❖ Connection of the switchboard to the fan power supply line (see para.15.3) with a suitable section cable (see table 2);
- ❖ Connection of the purifier to the suction line;
- ❖ Connection of the purifier to the ejection line;
- ❖ Connect tank and overflow drain pipe to suitable disposal vessels;
- ❖ Connect the front sleeve to the pipe for the supply of running water for the maintenance of the water level inside the tank. It is recommended to install a valve on the water supply line.
- ❖ The water level inside the tank is determined by a float set by the manufacturer according to the suction rate of the purifier. There is a level indicator on the purifier where two electrical sensors are located at the correct levels. Check that the position of the sensors is in accordance with the indications in section 7.3. If the level is not as shown in "Figure 11 - Level Sensor Position", adjust the position of the sensors by loosening the screw on the side of the sensor block and moving it to the correct position. Once the sensors are positioned, tighten the screw on the side of the sensor blocks.

For commissioning proceed to read the next paragraph.

16.2 Procedure for first commissioning of the system

Once the filter has been positioned and connected, as described in section 16.1, follow the procedure below to check the operating and minimum water levels and adjust the level and flow sensors if necessary.

The filter is supplied with a level setting made for the flow rate value for which the filter is designed.

The following procedure must be carried out with the electrical panel switched on, the Hoover switched off and the water flow solenoid valve connected to the power supply.

1. Start by filling the purifier containment tank with water using the sleeve on the side of the filter (nr8 Figure 12 - Filter modules).
2. When filling begins, the "low level" indicator light on the control panel should be on.
3. During filling, check that the "low level" light goes off when the minimum water level indicated in "Figure 13 - Level sensor position" is reached.
4. While continuing to fill the water, check that when the water level indicated in "Figure 14 - Level sensor position" is reached, the water tap closes by triggering the solenoid valve.
5. The filter is tested and adjusted at the factory, but it is necessary to check the setting of the float to avoid any changes due to transport or other reasons.
6. After checking the operating levels, the fan can be started with the whole suction and discharge line connected.
7. Adjust the drive so that the suction air flow does not exceed the value for which the machine has been designed. The maximum value of the suction air flow must not exceed the value indicated in table 2 par.7.
8. When the fan is turned on, the level indicated by the water level indicator increases due to the passage of air inside the filter; check that the level is stable and that the purifier does not work abnormally.

If abnormal situations occur, follow the procedures below:

The flow rate is at its maximum value: with the fan off but the panel powered, lower the operating level (1/2 cm at a time) by lowering the level sensor of the water tank "Figure 15 - Level sensor position" and letting the water flow out.

Flow rate lower than the maximum value: with the fan off but the panel powered, the operating level "Figure 16 - Level sensor position" must be increased (1/2 cm at a time) so that more water can enter.

11. Once the value of the frequency at which the fan processes the operating flow has been determined (less than or equal to the maximum value), it is advisable to mark it on the following table so that it can be entered if necessary.

Débit	_____ m ³ /h	Fréquence de l'onduleur	_____ Hz
-------	-------------------------	-------------------------	----------

17. Utilization



	<p>ATTENTION CHECK CAREFULLY THAT THE SUCTION PLACE CONNECTED TO THE MACHINE ARE OPENED, FREE OF FOREIGN BODIES AND UNABLE TO SUCK ANITHING NOT SPECIFY IN CHAPTER 8 “DESIGNATED USE” IMPROPER USE MAY DAMAGE THE MACHINE, AND ALSO INVOLVES THE END OF WARRANTY.</p>
---	--

Check for water supply.
 Press the start button.
 After treatment, press the stop button.

18. Maintenance

	<p>ATTENTION READ CAREFULLY SECTION 2 BEFORE DOING ANY MAINTENANCE.</p>
	<p>ATTENTION ALL MAINTENANCE AND REPAIR WORKS SHOULD BE DONE BY A PROFESSIONAL WHO HAS READ AND UNDERSTOOD THE MANUAL OF USE AND MAINTENANCE.</p>

18.1 Collection tank

	<p>AFTER MAINTENANCE HAS BEEN COMPLETED CHECK THAT THE DOORS ARE PROPERLY CLOSED.</p>
	<p>Follow current waste legislation for sludge disposal.</p>

The slag collection tank is equipped with a 2"pipe. This pipe must be connected to a suitable sludge collection tank and disposed of as indicated in the chapter 22.

18.2 Maintenance operations

	ALL MAINTENANCE AND REPAIR WORK SHALL BE CARRIED OUT BY SPECIALISED PERSONNEL WHO HAVE SEEN THE OWNER'S MANUAL.
	ALL MAINTENANCE AND REPAIR WORK MUST BE CARRIED OUT BY SPECIALISED PERSONNEL EQUIPPED WITH ADEQUATE PERSONAL PROTECTIVE EQUIPMENT (PPE) SUCH AS SPECTACLES, MASKS, GLOVES AND SLIP-RESISTANT SHOES. ASSESSING OTHER MEANS OF INDIVIDUAL DEVICES ACCORDING TO THE POLLUTANT TREATED BY THE FILTER.

Access to the filters is through the doors on the purifier structure.



The frequency of intervention depends on the amount of dust being extracted.

It is recommended to empty the tank when 40 mm of deposit is reached at the bottom of the tank. However, empty every 3 months.

The maintenance must be carried out according to table that follows.

Period [hours]	Intervention type	Filter
40	Visual inspection of the internal situation of the filter by opening the different doors. The visual inspection must be carried out with the filter switched off and the electrical panel not powered. If the visual inspection reveals accumulations of dust/deposits, follow the steps described in point 18.3.	Profiles and tanks
300	Check the integrity of the droplet filter in the machine	Droplet separator
300	Check dredging conveyor (optional)	Dredger
300	Control of material deposits inside the filter and total water change.	Depurator
700	Overall check filter integrity and bolts tightening	Depurator

Table 5 – Maintenance

	AFTER MAINTENANCE HAS BEEN COMPLETED CHECK THAT THE FILTER DOOR HAS BEEN FITTED AND PROPERLY SECURED
	Follow current waste regulations for the disposal of filter elements and waste fluids/sludge

18.3 Check and filter cleaning

Periodic (depending on workload)

The frequency of interventions depends on the dust load of the vacuum cleaner.

It is recommended to empty the tank when 40 mm of deposit is reached at the bottom of the tank. However, empty every 3 months.

Turn off the water make-up system, switch off the Hoover and completely disconnect the electrical cabinet from the supply line. With the system switched off :

1. Using the door (3), check that there are no obstructions to the passage of air and agitate the water and sludge at the bottom of the tank.
2. Using the door (3), clean the internal profiles that allow the inertial filtration; the cleaning can be done with running water and NON-abrasive tools (do not use solvents or other products that could damage the surfaces or release substances that are dangerous for the filter operation). Once the cleaning is finished, close the door and lock it with the special handwheel; do not exert excessive pressure on the seal to avoid damaging it.

The frequency depends on the suction dust load.

3. Remove the cover (4) of the external casing containing the level indicator and check that there are no obstructions to the passage of water and/or deposits that prevent the float from working properly. Remove any deposits and wash the inside of the tray with water, taking care not to damage the float.
4. Using the door (5), remove the drop separator and clean it with low pressure water jets; if the deposits cannot be removed, replace it. Clean the guides under running water to remove any deposits. Insert the drip separator, ensuring that it is correctly aligned and fully inserted. Close the door by securing the appropriate nuts, but taking care not to crush the seal too much as this may compromise its functionality.
5. For maintenance work without emptying the filter, once you have finished cleaning the filter, check that the water level is below the operating level (Figure 15 - Level sensor position) so that the machine itself determines the appropriate water level. If this is not the case, empty the tank via the tap on the float box.
6. For maintenance work with tank emptying. Empty filter using tap (1) and dispose of sludge according to regulations.
7. Check the interior of the filter for cleanliness and remove any residual dust.
8. Fill the tank.
9. Replace the machine, checking carefully that the doors are closed.

If present, dredge it:

When working on the mud dredger, read the relevant manual carefully.

Repeat steps 1 to 5 above.

10. Turn on the electrical panel and start the dredger to remove the material deposited on the bottom during cleaning. Check that the dredger is working properly and that there are no dust deposits on the bottom and moving parts.
11. Empty tank using tap (1) and special tap on sludge body. Dispose of sludge according to regulations.
12. By opening the doors, check that the sludge dredger is working properly and that there are no dust deposits on the bottom and moving parts.
13. After cleaning, ensure that all doors are closed. For doors with handwheels, do not apply excessive pressure to the seal to avoid damaging it.
14. Fill the tank.
15. Replace the machine, checking carefully that the doors are closed.

For the disposal of the waste retained by the filter, contact the competent bodies or specialised firms in accordance with regional, national or European regulations. The maintenance and/or replacement of the filters is periodic.

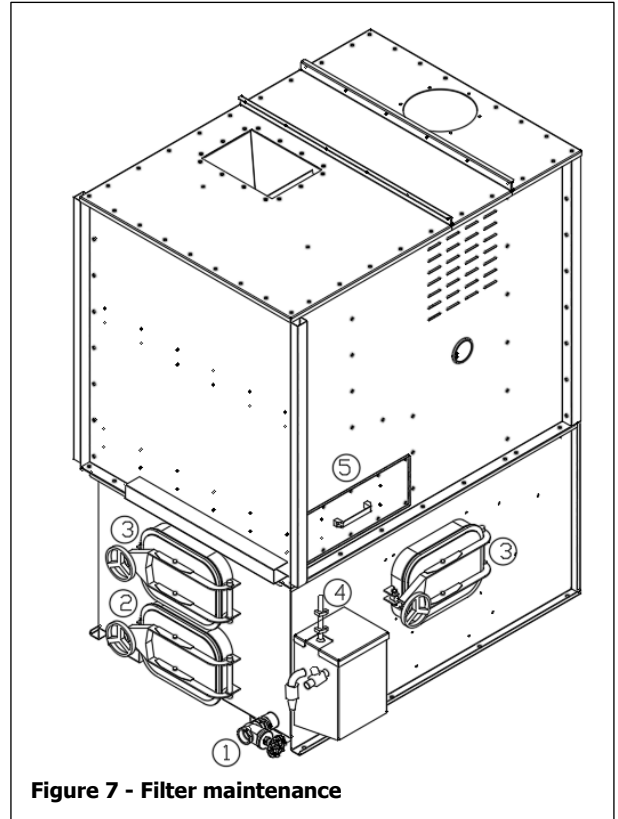

Figure 7 - Filter maintenance

Maintenance must be carried out according to the quantity of dust produced by the operations to which the filter is subjected.



If the machine is stopped for a long period of time, maintenance work must be carried out to avoid dust settling.

The maintenance and/or replacement of the filters is periodic. Maintenance must be carried out according to the amount of dust produced by the processes to which the filter is subjected.

In case of prolonged downtime perform maintenance to avoid sedimentation of dust.

18.4 Maintenance of the fan

Ordinary maintenance

	<p><u>ATTENTION</u> Before starting the maintenance operations, stop and empty the machine ensuring that it is in complete safety. Perform any type of intervention exclusively with the machine turned off and disconnected from the power supply. Before starting make sure that metal foreign matter has not remained inside. Check the gaskets after having removed the bolted parts between them; which time the gaskets no longer guarantee a perfect seal provide for the replacement.</p>
	<p><u>WARNING</u> It is forbidden to stop the machine before the fluid inside it has not reached a temperature of less than 60 ° C, to avoid risks to the operator and that the excessive heat damages the engine. If this temperature cannot be guaranteed, external cooling systems must be provided. During a period of standstill of the machine, in case the temperature inside the machine rises, it is necessary that the user carry it, by his own means, to values of less than 60 C before starting</p>

Control of minimum distances

	<p><u>WARNING</u> At each maintenance operation it is necessary to check that the gaps between the moving and fixed parts remain greater than 1% of the diameter of possible contact and in any case never less than 2mm. in the event of any reduction in the gaps, the causes may be as follows:</p> <ul style="list-style-type: none"> • screws may have loosened because during normal operation, the machine generates vibrations that can interfere with the proper maintenance of the tightening of the bolts, so a realignment may be necessary. • The machine could have deformed and therefore some component or the whole structure would have to be replaced. <p>Contact the technical office before any operation</p>
---	--

Cleaning

	<p><u>WARNING</u> For the dust removing from the wet collector be careful to don't disperse it in the environment. The end user it's responsible of the choice of cleaning product depending on the type of the extraction system and on the dust threatened. During cleaning operation, the operator must wear suitable personal protective equipment, specifically must wear a mask to protect respiratory tract with efficiency (depending on laws and on dust) and also with suitable gloves. The affixing of indications regarding the nature of the danger is mandatory and is the responsibility of the installer, who is aware of the real composition and dangers of the treated dust. It is recommended to constantly check the impeller cleaning status. When the machine comes into contact with materials that can adhere to the joints, it is necessary that this is cleaned frequently; the possible stratification of material, dust, fatty substances etc. on the impeller causes imbalance resulting in damage to the transmission equipment and/ or the</p>
---	---

electric motor. During cleaning, it is necessary to intervene in a uniform manner on all parts of the rotary; any residue in limited points can lead to imbalance of the impeller. It should be carefully checked that after cleaning, during restarting, the vibrations generated by the machine have not increased: if the cleaning has not been accurate, imbalances can be generated that affect the balance of the impeller. In this case, the cleaning operation must be carried out more meticulously.

Vibration control



Check that the vibrations produced by the machine do not degenerate; in this case check that the installation or the execution of maintenance operations has been carried out correctly.

The causes could be:

- Worn bearings (20,000 hours of service under optimal working conditions)
- The deranged impeller (change or replace).

Maintenance work.

Use the following table as a reference for the timing of maintenance operations.

Type of verification	Method	Frequency	Date and time of maintenance
General control of fan status	Visual	150 hours	
Distance control (GAPS)	Visual	150 hours	
Cleaning	Manual	See specific paragraph	
Verification of continuity of the equipotential circuit for earthing	instrumental	2000 hours	
Checking the tightening of the bolts	Manual	150 hours	
Check the Seal Test Status	visual	150 hours	

Table 6 - Maintenance work on the vacuum cleaner

For access to fan:

- Disconnect exhaust duct from fan.
- Remove top panel with handles by unscrewing bolts on perimeter.
- Remove the remaining upper panel by unscrewing the bolts on the perimeter.
- Unscrew the bolts holding the hose to the filter structure (A).
- Unscrew the bolts holding the fan housing to the filter structure (B).

At this point, the fan can be removed using suitable lifting equipment and hooking points on the fan's electric motor. For maintenance on the fan, please refer to the relevant manual.

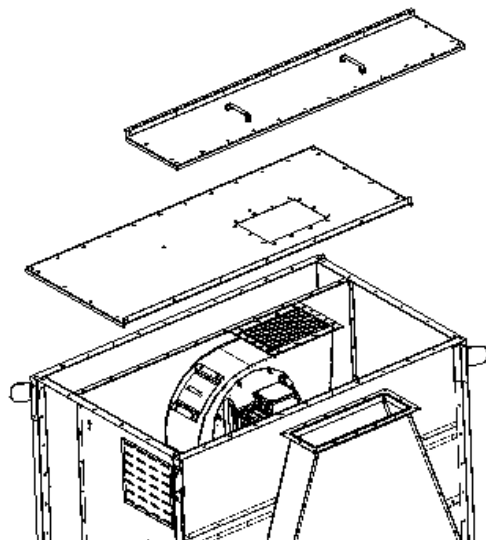

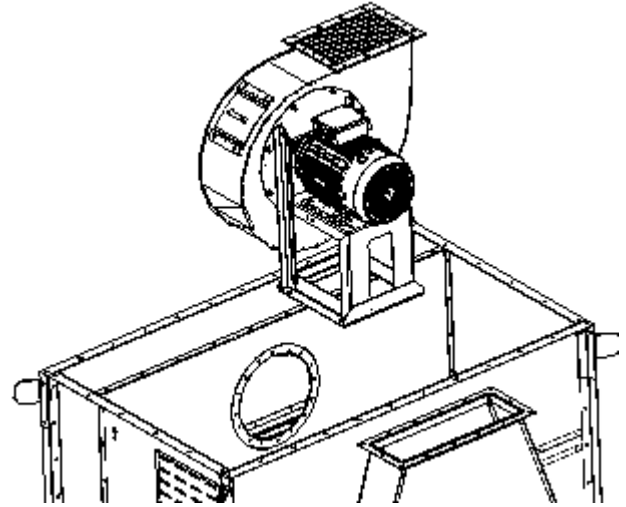
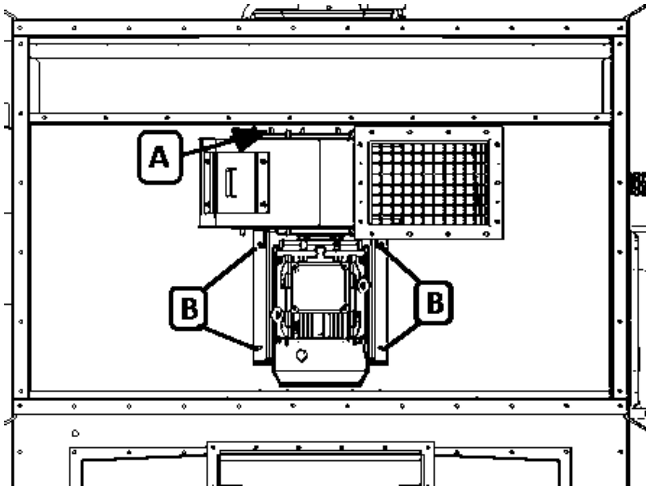

18.5 Maintenance of dredging conveyor (optional)

	<p>ALL MAINTENANCE AND REPAIR WORK SHALL BE CARRIED OUT BY SPECIALISED PERSONNEL WHO HAVE SEEN THE OWNER'S MANUAL</p>
	<p>ALL MAINTENANCE AND REPAIR WORK SHALL BE CARRIED OUT BY SPECIALISED PERSONNEL WHO HAVE SEEN THE OPERATOR'S MANUAL</p>
	<p>ALL MAINTENANCE AND REPAIR WORK MUST BE CARRIED OUT BY SPECIALISED PERSONNEL EQUIPPED WITH ADEQUATE PERSONAL PROTECTIVE EQUIPMENT (PPE) SUCH AS SPECTACLES, MASKS, GLOVES AND SLIP-RESISTANT SHOES. ASSESSING OTHER MEANS OF INDIVIDUAL DEVICES ACCORDING TO THE POLLUTANT TREATED BY THE FILTER.</p>
	<p>BEFORE ANY INTERVENTION IS CARRIED OUT, MAKE SURE THAT THE POWER SUPPLY IS DISCONNECTED AND CANNOT IN ANY WAY BE REPLENISHED.</p>

Maintenance operations to be performed on dredging conveyor, are essential to preserve the proper functioning of the device especially in those places where there may be a greater accumulation of sludge and/or chips that can be cause of jamming of the moving parts and oxidation of components.
 To know the type of operations to be performed, their frequency and procedures, please refer to the dedicated manual or contact the technical office providing the serial number and filter order.

19. Non-ionizing radiation

The machine does not emit any kind of ionizing or non-ionizing radiation. If the intake engine is present, the intake engine manufacturer shall ensure its electromagnetic compatibility and compliance with non-ionizing emission standards.

20. Assembly/Disassembly

Authorised staff

The assembly and disassembly of the machine must be carried out by qualified, trained, qualified and knowledgeable personnel of the procedures indicated in this manual. The minimum number of staff employed in such operations shall be three.

Disassembly operations

For a correct disassembly of the machine follow the following points:

- ❖ Disconnect the machine from the power line and the water supply line;
- ❖ Empty the collection tank, by means of the drain tap, in special containers and clean completely the inside of the tank and the filters;
- ❖ Disconnect the purifier from the intake line;
- ❖ Disconnect the purifier from the ejection line;
- ❖ Disconnect drain pipe and overflow to special containers;
- ❖ Disconnect the front hose to supply running water to maintain the water level inside the tank;
- ❖ Delete/unplug any other item connected to, but not belonging to, the filter;

21. Search and elimination of system defects

The variability of defects that may occur during the operation of the machine, or its components, is wide. The most common defects are dealt with below, indicating the probable causes and their corrective actions. If, despite the suggested operations, the anomaly persists, it is advisable to contact Secureair® by GAMMA IMPIANTI S.r.l. indicating the defect and the operating conditions of the machine.

Defect	Causes	Solution
Switching off the machine	No power supply	Check the connection to the power line
	No power supply because the magneto thermic switch has tripped	Reset the circuit breaker. If the problem persists contact uff. tecn. aut.
	Blown fuse	Replace burned fuse
	Cable disconnected	Contact the authorised technical office
	Error message on inverter display	Contact the authorised technical office
	Minimum level indicator activated (optional)	Operation of the water make-up solenoid valve; Operation of the level maintenance sensor on the level gauge; Operation of the minimum level sensor on the level gauge; Water in the user's water lines; Opening of the tap (if any) installed in the user's water system; Fill with water and check.
Overflow level indicator light on	Discharge water by opening 3/4" overflow tap on float box and/or 2" water discharge tap until water level is below operating level. Check the operation of the water make-up solenoid valve. Check the functioning of the level maintenance sensor on the level indicator.	
Insufficient aspiration	Closed suction point dampers	Open dampers suction points
	Obstructed expulsion grille	Remove the obstruction
	Clogged filters	Verify the functioning of the cleaning system. Replace filters

	Direction of rotation of the aspirator opposite	Verify par.9.4
	Suction and / or expulsion line blocked.	Remove the obstruction
	Inverter adjusted to frequencies other than initial settings	Set inverter to initial operating frequency
The engine won't start	Electric panel not powered	Power the electrical panel
	Internal cable with electrical box disconnected	Contact the authorised technical office
	Burned engine	Contact the authorised technical office
	Error message on inverter display	Contact the authorised technical office
	The minimum level indicator is lit	Fill with water and check: presence of water in the user's water supply system operation of the mechanical float opening of the valve (if any) installed in the user's water system
	Overflow level indicator light on	Discharge water by opening 3/4" overflow tap on float box and/or 2" water discharge tap until water level is below operating level. Check the operation of the water make-up solenoid valve. Check the functioning of the level maintenance sensor on the level indicator.
Increased vibration or fan noise	Change in initial conditions of the plant's load losses.	Check par. 10.2.
Dust or slag escapes from the discharge	Damaged filters	If the problem persists please contact the authorised technical office
	Intake flow rate not suitable for the pollutant	Replace filters
Dredging conveyor not working (optional)	Stuck material	Contact the authorised technical office
	Burned engine	Remove the obstruction

Figure 8 - Identification and resolution of problems

22. Waste disposal

The waste produced by the plant consists of mud consisting of dust and water and must be periodically disposed of by the user through an authorized carrier, after analysis of the waste. Contact the relevant bodies or specialist firms.

As regards the disposal of the filters used, contact the relevant bodies or specialist firms.

Secureair® by GAMMA IMPIANTI S.R.L.

Via Stroppiana, 15 - 10071 Borgaro Torinese (TO)

Tel. 0114502031 - fax. 0114703927

email: info@secureair.it – website: www.secureair.it

Attachment 2 – Error reporting

If you find some errors in this manual please send this card

Article:

Data:

N° revision:

N° page:

Vostri dati:

Error description:

Spedire questo foglio,
completo nei suoi dati e
con eventuali allegati, a:

Send this form, complete in
its data and any
attachments to:

Nous Vous prions
d'envoyer cette page
complète des éventuelles
pièces jointes à:

Enviar este formulario,
completo en sus datos a:

Secureair by GAMMA IMPIANTI S.R.L.

Via Stroppiana, 15 - 10071 Borgaro Torinese (TO) - Tel. +39 011 4502031 Fax +39 011 4703927
 email: info@secureair.it – website: www.secureair.it